

# 80GHz Radar Level Meter

Assist in Digital Management of Industrial Materials

# Content

Company Profile_____	02	Housing Form_____	11
Company Qualifications____	03	Installation Requirements__	12
Measuring Principle_____	04	Electronic Components____	14
Product Advantages_____	05	Instrument Debugging_____	22
Instrument Profile_____	06	Structure Size_____	24



## Company Profile

RETTAR is an intelligent technology company that continuously achieves technological innovation in the field of industrial measurement with leading AI and radar technology. The company was founded in 2007, headquartered in Beijing, and originated from the Testing and Electronic Technology Research Institute of the Department of Automation at Tsinghua University. It has established a technology research and development center that serves global enterprises, owns 185 technology patents and intellectual property rights, and has obtained multiple international certifications.

The company focuses on automated measurement and control products such as radar level meters and 3D visual scanners, and has independently developed and produced nearly a hundred products to meet the needs of customers in various industrial measurement scenarios. Through the innovative technology of the R&D center, the company tailors customized solutions for customers and is a technological innovator in the field of industrial automation measurement and control in China.

RETTAR has a wide range of products, including 3D visual scanners, high-frequency radar level meters, micro-wave level meters, density meters, thermometers, interface meters, tank side controllers, and intelligent management systems. Now, RETTAR has cooperated with nearly 2000 domestic and foreign customers, and its products and solutions are widely used in fields such as oil and gas, electricity, metallurgy, chemical industry, building materials, coal, grain, feed, food and beverage, pharmaceuticals, environmental protection, mining, cement, etc.

# Company Qualifications



High Tech Enterprise Certificate



EU Trademark Certificate



Intellectual Property Pilot Unit



Invention Patent



Software Copyright



Product Measurement Certificate



ISO Certificate



Product Explosion Proof Certificate



Product Measurement Report



CE Certificate



Member of the HART/FF Foundation



TÜV SIL Engineer Certificate

# Measuring Principle

The CPR6400 and CPR6900 series radar level meters use FMCW frequency modulated continuous wave technology for 80 GHz radar level meters. The radar emits a 76-81GHz high-frequency microwave signal with linear frequency modulation, which is emitted from the radar antenna. When the microwave signal encounters the surface of the measured medium, some of its energy is reflected back by the surface of the medium and received by the radar antenna. A part of the microwave transmitting signal in radar is mixed with the received signal to obtain the difference frequency signal. The differential frequency signal is obtained by Fourier transform algorithms such as FFT or DFT to obtain the differential frequency spectrum signal, thereby obtaining the frequency difference. According to the linear frequency modulation signal frequency difference is proportional to time thus the time difference is obtained. Based on the time difference and the distance between the antenna and the surface of the measured medium, the distance between the antenna and the surface of the measured medium can be calculated.

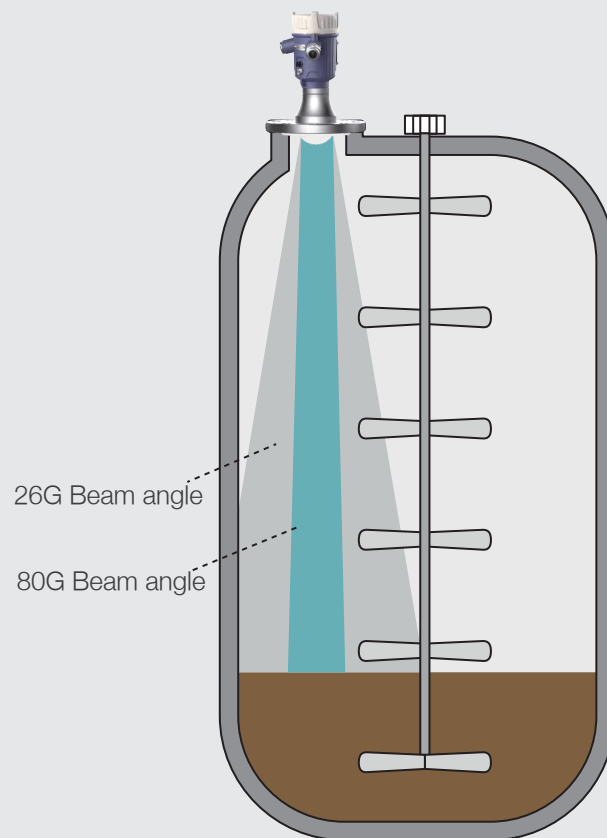

# Product Advantages

## High focus:

The min beam angle can reach 3 °

- ◆ Suitable for installation in containers with obstacles such as stirring, heating pipes, and ladders. A smaller beam angle allows the beam to avoid internal obstacles, without interfering echoes, ensuring accurate measurement by the instrument.
- ◆ Suitable for installation of long risers.
- ◆ Suitable for glass window installation.

## Multiple debugging methods

- ◆ Debugging via Bluetooth connection to radar (mobile phone, tablet).
- ◆ Debugging through upper computer software (RS485).
- ◆ Debugging through a HART communicator can display the echo curve.
- ◆ LCD debugging.
- ◆ Tank side monitor debugging.

## Powerful computing power:

triple-core quad-core

- ◆ LCD display, mainboard, microwave board, each with an independent MCU
- ◆ Both the LCD and mainboard have a single ARM core, while the microwave board has a dual ARM core

## Multi echoes processing capability

- ◆ Used in conjunction with corresponding instruments, it can output the measured value of solid level and liquid level.
- ◆ Support switch quantity/  
4...20mA/HART/RS485

# Instrument Profile

 CPR6400

Radar Liquid Level Meter With Rod Antenna



Integrated Radar Liquid Level Meter

Application	Corrosive liquid in small containers with simple process conditions	Slightly corrosive liquids with complex process conditions
Max Measuring Range*	120m	120m
Antenna Form/Material	Rod antenna/PP/PTFE	Thread integrated antenna/ Stainless steel 316L, PP/PTFE/PEEK
Beam Angle	Beam angle 7° (thread G1½, 1½ NPT) Beam angle 3° (thread G3, 3NPT)	Beam angle 7° (thread G1½, 1½ NPT) Beam angle 3° (thread G3, 3NPT)
Contact Medium Material	PP/PTFE	Stainless steel 316L, PP/PTFE/PEEK
Process Connection	Thread/Flange connection	Thread/Flange connection
Process Temperature*	-40°C...+200°C	-40°C...+200°C
Process Pressure*	-1...3bar	-1...20bar
Accuracy	±2mm	±2mm
Resolution Ratio	1mm	1mm
Response Time	< 2s	< 2s
Frequency Range	76~81GHz	76~81GHz
Signal Output	4...20mA/HART/RS485	4...20mA/HART/RS485
Display Debugging	LCD, Tank side monitor, Phone (bluetooth) Upper computer software	LCD, Tank side monitor, Phone (bluetooth) Upper computer software
Electrical Connection	M20*1.5 (Cable diameter 6~12mm) ½ NPT	M20*1.5 (Cable diameter 6~12mm) ½ NPT
Ingress Protection	IP67	IP67
ATEX	Ex ia IIC T6/T2 Ga Ex d ia IIC T6/T2 Gb	Ex ia IIC T6/T2 Ga Ex d ia IIC T6/T2 Gb

## CPR6400



Radar Liquid Level Meter With Plastic Horn Antenna    Radar Liquid Level Meter With Process Sealed Antenna

Application	Corrosive liquids in small containers, without pressure vessel or open container.	Highly corrosive liquids with complex process conditions
Max Measuring Range*	120m	120m
Antenna Form/Material	Plastic horn antenna/PP/PTFE	Process sealed antenna/Stainless steel 316L, PP/PTFE/PFA
Beam Angle	Beam angle 3° (Flange DN80)	Beam angle 7° (Flange DN50) Beam angle 3° (Flange DN80)
Contact Medium Material	PP/PTFE	Stainless steel 316L, PP/PTFE/PFA
Process Connection	Flange connection or installation of gantry crane	Flange connection
Process Temperature*	-40°C...+130°C	-40°C...+200°C
Process Pressure*	-1...3bar	-1...25bar
Accuracy	±2mm	±2mm
Resolution Ratio	1mm	1mm
Response Time	< 2s	< 2s
Frequency Range	76~81GHz	76~81GHz
Signal Output	4...20mA/HART/RS485	4...20mA/HART/RS485
Display Debugging	LCD, Tank side monitor, Phone (bluetooth) Upper computer software	LCD, Tank side monitor, Phone (bluetooth) Upper computer software
Electrical Connection	M20*1.5 (Cable diameter 6~12mm) 1/2 NPT	M20*1.5 (Cable diameter 6~12mm) 1/2 NPT
Ingress Protection	IP67	IP67
ATEX	Ex ia IIC T6/T2 Ga Ex d ia IIC T6/T2 Gb	Ex ia IIC T6/T2 Ga Ex d ia IIC T6/T2 Gb



Radar Liquid Level Meter With Hygienic Antenna

Application	Liquid measurement in the food and pharmaceutical industries
Max Measuring Range*	120m
Antenna Form/Material	Hygienic antenna/Stainless steel 316L、PTFE
Beam Angle	Beam angle 7° (Clamp 2") Beam angle 3° (Clamp 3")
Contact Medium Material	Stainless steel 316L、PTFE
Process Connection	Clamp connection
Process Temperature*	-40°C...+200°C
Process Pressure*	-1...25bar
Accuracy	±2mm
Resolution Ratio	1mm
Response Time	< 2s
Frequency Range	76~81GHz
Signal Output	4...20mA/HART/RS485
Display Debugging	LCD、Tank side monitor、Phone (bluetooth) Upper computer software
Electrical Connection	M20*1.5 (Cable diameter 6~12mm) 1/2 NPT
Ingress Protection	IP67
ATEX	Ex ia IIC T6/T2 Ga Ex d ia IIC T6/T2 Gb

### Special Instructions

- 1、 The actual measurement range of the instrument depends on antenna size, medium reflectivity, instrument installation location, and possible interference reflections. ± 2mm is the instrument laboratory accuracy under standard conditions.
- 2、 \*Process Temperature、 \*Process Pressure、 \*Actual measuring distanceThe actual measurement distance are influenced by selection, on-site measurement, and operating conditions.

## CPR6900



Radar Solid Level Meter With Plastic Horn Antenna



Integrated Radar Solid Level Meter

Application	Measurement of block and powder materials with simple process conditions	Measurement of block and powder materials with complex process conditions
Max Measuring Range*	120m	120m
Antenna Form/Material	Plastic horn antenna/PP/PTFE	Integrated thread antenna/ Stainless steel 316L、PP/PTFE/PEEK
Beam Angle	Beam angle 3° (Flange DN80)	Beam angle 3° (Thread G3/3NPT)
Contact Medium Material	PP/PTFE	Stainless steel 316L、PP/PTFE/PEEK
Process Connection	Flange connection or installation of gantry crane	Thread or flange connection
Process Temperature*	-40°C...+130°C	-40°C...+200°C
Process Pressure*	-1...3bar	-1...16bar
Accuracy	±2mm	±2mm
Resolution Ratio	1mm	1mm
Response Time	< 2s	< 2s
Frequency Range	76~81GHz	76~81GHz
Signal Output	4...20mA/HART/RS485	4...20mA/HART/RS485
Display Debugging	LCD、Tank side monitor、Phone (bluetooth) Upper computer software	LCD、Tank side monitor、Phone (bluetooth) Upper computer software
Electrical Connection	M20*1.5 (Cable diameter 6~12mm) 1/2 NPT	M20*1.5 (Cable diameter 6~12mm) 1/2 NPT
Ingress Protection	IP67	IP67
ATEX	Ex ia IIC T6/T2 Ga Ex d ia IIC T6/T2 Gb Ex iaD tD A21 IP67 T80°C/T290°C Ex d ia IIC T6/T2 Gb、Ex iaD tD A21 IP67 T80°C/T290°C	Ex ia IIC T6/T2 Ga Ex d ia IIC T6/T2 Gb Ex iaD tD A21 IP67 T80°C/T290°C Ex d ia IIC T6/T2 Gb、Ex iaD tD A21 IP67 T80°C/T290°C

 CPR6900

Radar Solid Level Meter With Rod Antenna



Radar Solid Level Meter With Universal Joint Antenna

Application	Measurement of block and powder materials with simple process conditions	Measurement of block and powder materials with simple process conditions
Max Measuring Range*	120m	120m
Antenna Form/Material	Rod antenna/PP/PTFE	Lens antenna/Stainless steel 316L、PP/PTFE
Beam Angle	Beam angle 3° (Thread G3、3NPT)	Beam angle 3° (adjustable beam angle)
Contact Medium Material	PP/PTFE	Stainless steel 316L、PP/PTFE
Process Connection	Flange connection or installation of gantry crane	Flange connection
Process Temperature*	-40°C...+200°C	-40°C...+200°C
Process Pressure*	-1...3bar	-1...3bar
Accuracy	±2mm	±2mm
Resolution Ratio	1mm	1mm
Response Time	<2s	<2s
Frequency Range	76~81GHz	76~81GHz
Signal Output	4...20mA/HART/RS485	4...20mA/HART
Display Debugging	LCD、Tank side monitor、Phone (bluetooth) Upper computer software	LCD、Tank side monitor、Phone (bluetooth) Upper computer software
Electrical Connection	M20*1.5 (Cable diameter 6~12mm) 1/2 NPT	M20*1.5 (Cable diameter 6~12mm) 1/2 NPT
Ingress Protection	IP67	IP67
ATEX	Ex ia IIC T6/T2 Ga Ex d ia IIC T6/T2 Gb Ex iaD tD A21 IP67 T80°C/T290°C Ex d ia IIC T6/T2 Gb、Ex iaD tD A21 IP67 T80°C/T290°C	Ex ia IIC T6/T2 Ga Ex d ia IIC T6/T2 Gb Ex iaD tD A21 IP67 T80°C/T290°C Ex d ia IIC T6/T2 Gb、Ex iaD tD A21 IP67 T80°C/T290°C

# Housing Form



Type	Single compartment	Dual compartment
Material Quality	Aluminium alloy/Stainless steel	Aluminium alloy/Stainless steel
Surface Material	Surface powder-coated	Surface powder-coated
Sealing Ring Material Quality	Silicon rubber	Silicon rubber
Instrument window	Tempered glass	Tempered glass
Ingress Protection	IP67	IP67
Application Range	Industrial environment	Industrial environment

# Installation Requirements

(1) If measuring liquids, it is best to choose an opening at a radius of 1/2 of the tank body. Choose a location for easy installation and wiring, and make it convenient for future disassembly and assembly. The distance between the instrument and the tank wall must be no less than 200mm

(2) If measuring solids, it is best to choose the larger of the opening placed away from the feeding port, 500mm away from the tank wall, and 1/10 of the tank height.

(3) There should be no obstacles within the beam angle of the antenna microwave transmission beam, so installation should avoid facilities inside the tank as much as possible, such as ladders, limit switches, heating equipments, brackets, etc. If it cannot be avoided, the "level confirm" is required during installation.

(4) The microwave beam emitted by the antenna needs to be far away from the feed stream. The highest material level of the tested material is lower than the blind spot of the instrument measurement (usually at the end of the antenna, and the low dielectric constant or blind spot of solid materials should be appropriately increased). The distance between the end of the antenna and the surface of the medium should be at least 100mm to ensure that the material does not contaminate the antenna.

(5) For liquid measurement, the installation of the instrument must ensure that the antenna is perpendicular to the surface of the measured medium. For solid measurement, try to ensure that the antenna is perpendicular to the surface of the measured medium.

(6) Instruments installed in explosion-proof areas must comply with the national installation regulations for explosion-proof hazardous areas.

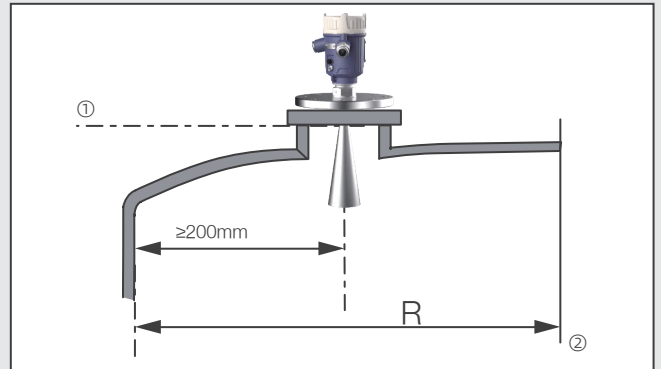

① Measuring datum plane ② Container center or axis of symmetry

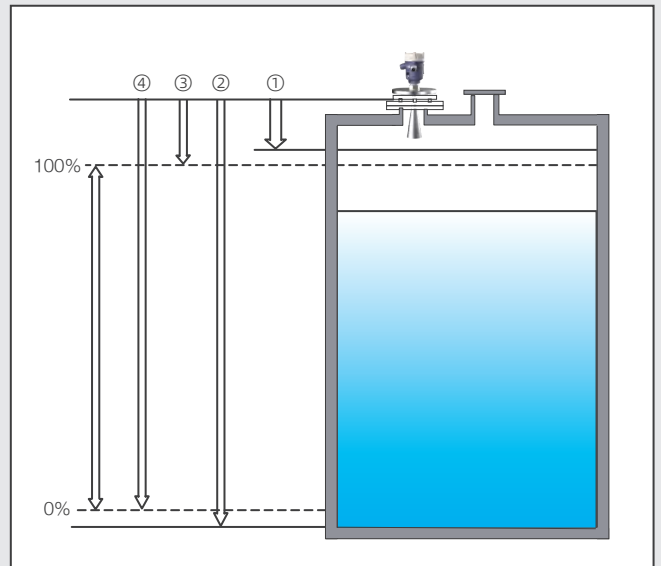

① High blind zone ② Low blind zone ③ High range ④ Low range



When using radar, it is important to ensure that the highest material level does not enter the measurement blind zone.

## Installation example



① Installation of Small Tank/Flange

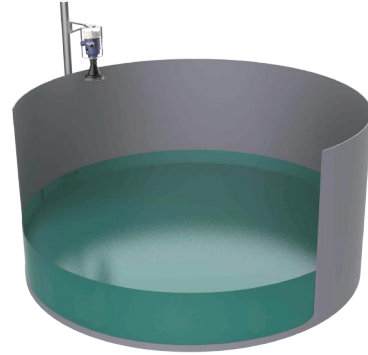

② Installation of Open Pool/Gantry Crane



③ Installation of Reactor/Flange



④ Installation of Large Solid Silo/Flange/Thread

# Electronic Components

The CPR6X00 series radar level meter adopts detachable electronic components for easy on-site replacement.

## (1) Two-wire system 4...20mA/HART

Supply Voltage: 20-28VDC

Connecting Cable: 4...20mA/HART(Two -wire system)

The instrument power supply and current signal share a two core cable.

The cable should be shielded with an outer diameter between 6-12mm. Ensure the sealing of the cable entry, and it is recommended to use standard two core cables for wiring. The recommended cable model is Belden3076F. For intrinsically safe types, a safety barrier must be added between the power supply and the instrument.

Shielded cables and grounding:

- ◆ Both ends of the shielded cable should be grounded.
- ◆ The grounding terminal block inside the instrument housing is used for cable shielding or grounding of a dedicated grounding wire.
- ◆ The external grounding terminal block of the instrument housing is used to complete the grounding between the instrument and the on-site ground.
- ◆ If there is grounding current, the shielding end of the shielded cable on the side away from the instrument must be grounded through a ceramic capacitor (such as InF1500V) to suppress low-frequency grounding current while still preventing high-frequency interference signals.

Single compartment two-wire housing (24V)

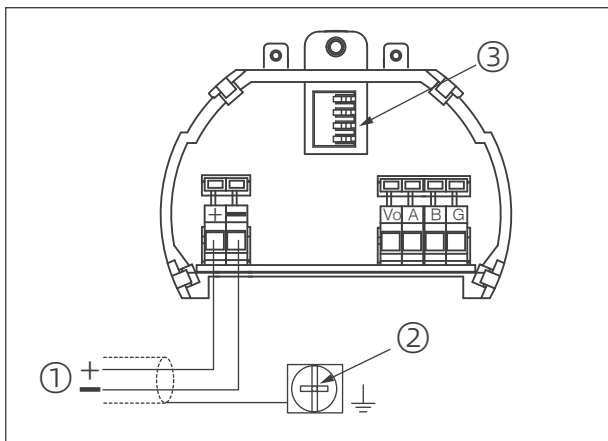

Diagram: Wiring compartment for single compartment two-wire housing

- ① 24V Power supply line
- ② Grounding screw inside the case
- ③ LCD connection module

Single compartment two-wire 4...20mA HART (24V)

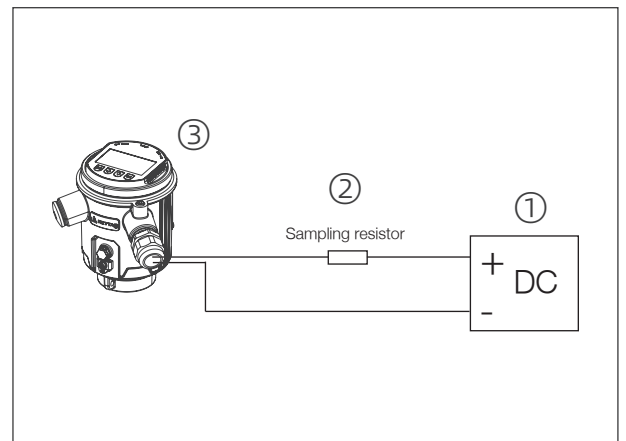

Diagram: Wiring compartment for single compartment two-wire housing

- ① 24V Power supply line
- ② HART Communication impedance ( $\geq 250\Omega$ ), pay attention to the max load
- ③ Radar level meter

Dual compartment two-wire housing (24V)

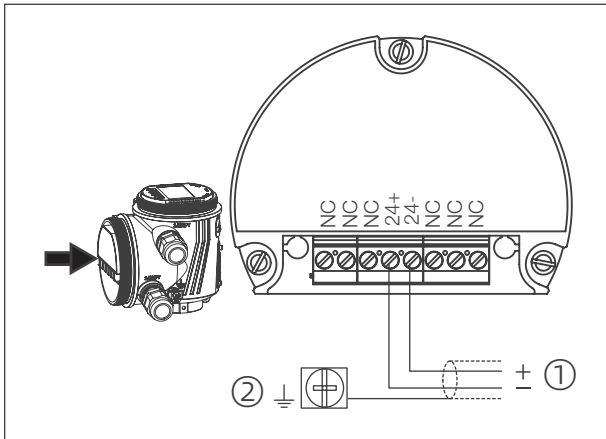

Diagram: Wiring compartment for dual compartment two-wire housing

- ① 24V Power supply line
- ② Grounding screw inside the case

Dual compartment two-wire 4...20mA HART (24V)

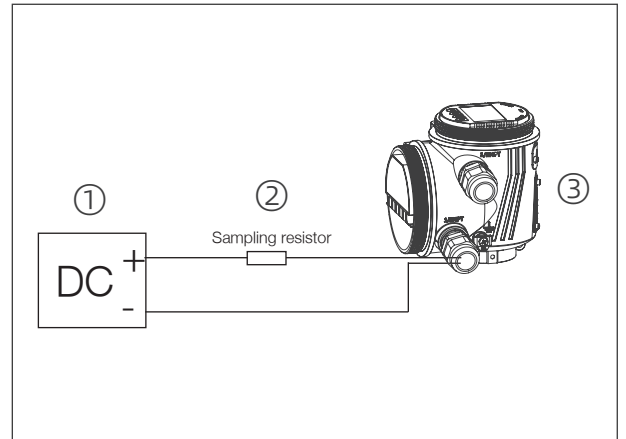

Diagram: Wiring compartment for dual compartment two-wire housing

- ① 24V Power supply line
- ② HART Communication impedance ( $\geq 250\Omega$ ), pay attention to the max load
- ③ Radar Level Meter

## (2) Four-wire system 4...20mA/HART

Supply Voltage: 220VAC or 20-28VDC

Connecting cable: 4...20mA/HART (four-wire system) The instrument power supply and current signal each use a two core cable.

The cable should be shielded with an outer diameter between 6-12mm. Cables should use cables with dedicated ground wires.

Shielded cables and grounding:

- ◆ Both ends of the shielded cable should be grounded.
- ◆ The grounding terminal block inside the instrument housing is used for cable shielding or grounding of a dedicated grounding wire.
- ◆ The external grounding terminal block of the instrument housing is used to complete grounding between the instrument and the on-site ground.
- ◆ If there is grounding current, the shielding end of the shielded cable on the side away from the instrument must be grounded through a ceramic capacitor (such as 1nF/1500V) to suppress low-frequency grounding current while still preventing high-frequency interference signals.

Dual compartment four-wire housing (24V)

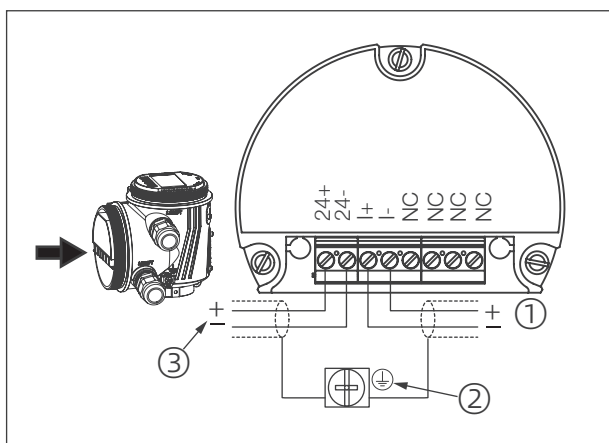

Diagram: Wiring compartment for dual compartment four -wire housing

- ① Current signal line
- ② Grounding screw inside the case
- ③ 24V Power supply line

Dual compartment four-wire 4...20mA HART (24V)

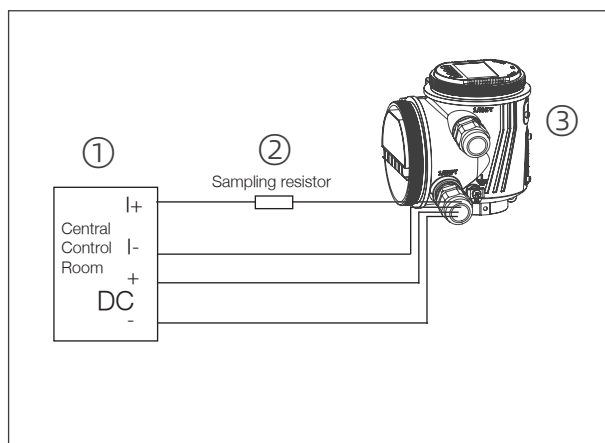

Diagram: Wiring compartment for dual compartment four -wire housing

- ① 24V Power supply and signal collection module
- ② HART Communication impedance ( $\geq 250R$ ), pay attention to the max load
- ③ Radar level meter

Dual compartment four-wire housing (220V)

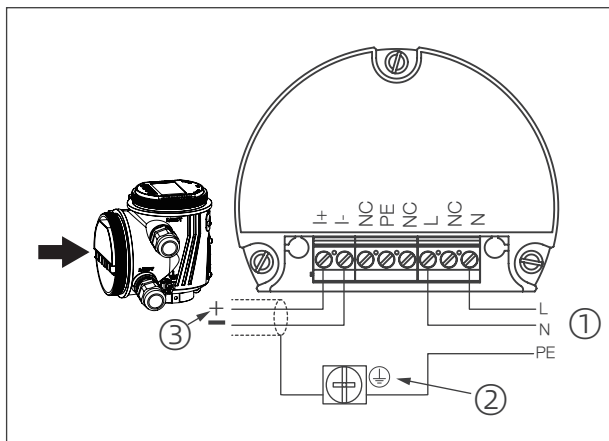

Diagram: Wiring compartment for dual compartment four -wire housing

- ① Current signal line
- ② Grounding screw inside the case
- ③ 220V Power supply line

Note: If the current signal is not connected to the central control room on site, it is necessary to short circuit I+and I- with wires!

Dual compartment four-wire 4...20mA HART (220V)

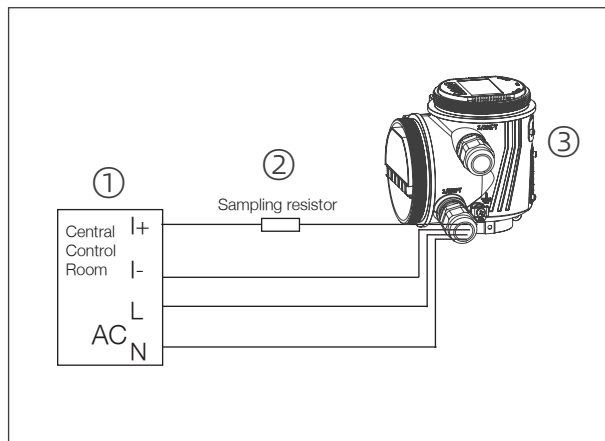

Diagram: Wiring compartment for dual compartment four -wire housing

- ① 220V Power supply and signal collection module
- ② HART Communication impedance ( $\geq 250R$ ), pay attention to the max load
- ③ Radar level meter

## (3) RS485 (Non-Isolated)

Output method: Modbus-RTU

Supply voltage: 20-28VDC

Connecting Cable:

- ◆ The power supply cable uses a separate two core cable
- ◆ RS485 requires the twisted pair cables suitable for RS485 communication for connection. If the on-site electromagnetic interference exceeds the standard of EN61326-1, shielded twisted pair cables are required.
- ◆ If multiple radars are connected to an RS485 line, the end of the radar needs to be connected in parallel with a 120ohm resistor.

Shielded cables and grounding:

- ◆ Both ends of the shielded cable should be grounded.
- ◆ The grounding terminal block inside the instrument housing is used for cable shielding or grounding of a dedicated grounding wire.
- ◆ The external grounding terminal block of the instrument housing is used to complete the grounding between the instrument and the on-site ground.
- ◆ If there is grounding current, the shielding end of the shielded cable on the side away from the instrument must be grounded through a ceramic capacitor (such as InF1500V) to suppress low-frequency grounding current while still preventing high-frequency interference signals.

Modbus Wiring diagram

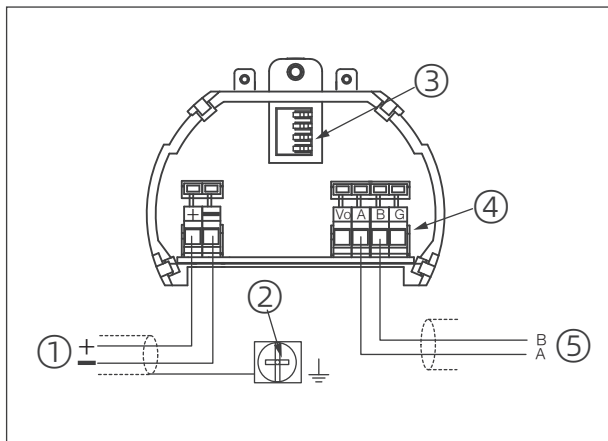

Diagram: Modbus wiring

- ① 24V Power supply line
- ② Grounding screw inside the case
- ③ LCD slider terminal block
- ④ 485 Signal wiring terminal block
- ⑤ 485 Signal line (2-core)

Two-wire system: Modbus Output

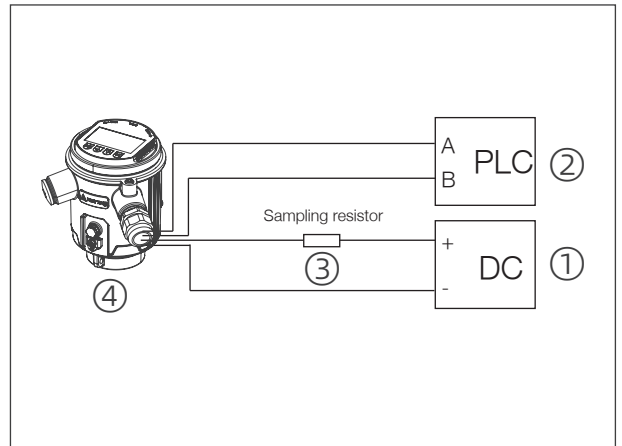
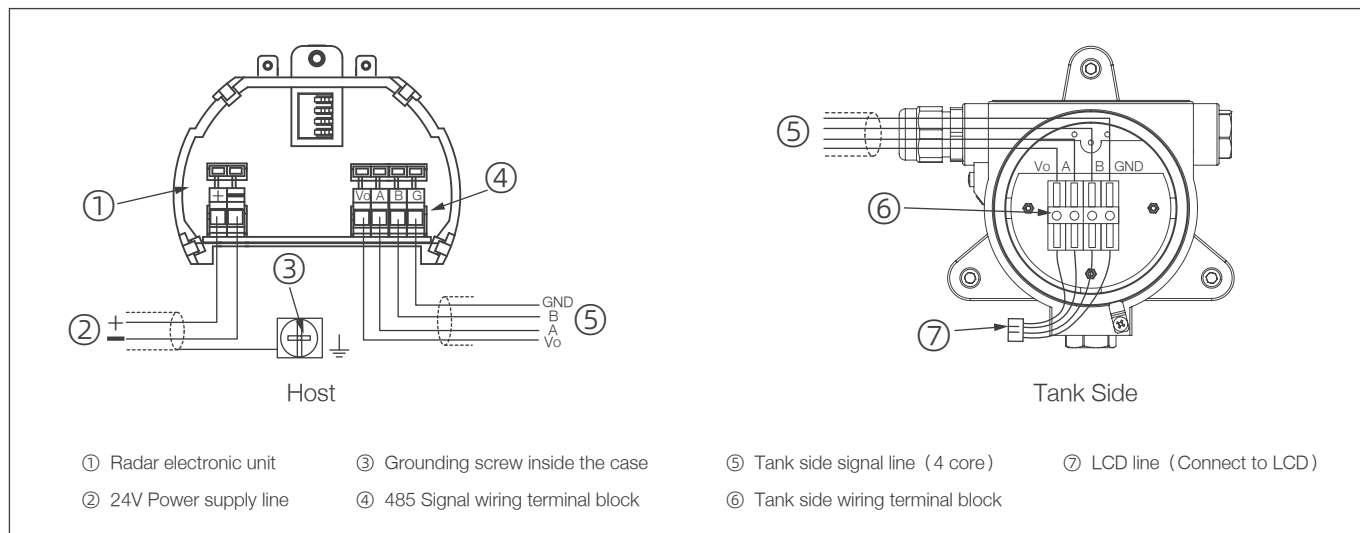

Diagram: Two-wire system Modbus output

- ① 24V Power supply line
- ② PLC
- ③ HART Communication impedance ( $\geq 250R$ ), pay attention to the max load
- ④ Radar level meter

(4) Remote display unit

24V Single compartment two-wire passive tank side wiring diagram



24V Single compartment two-wire system Modbus output

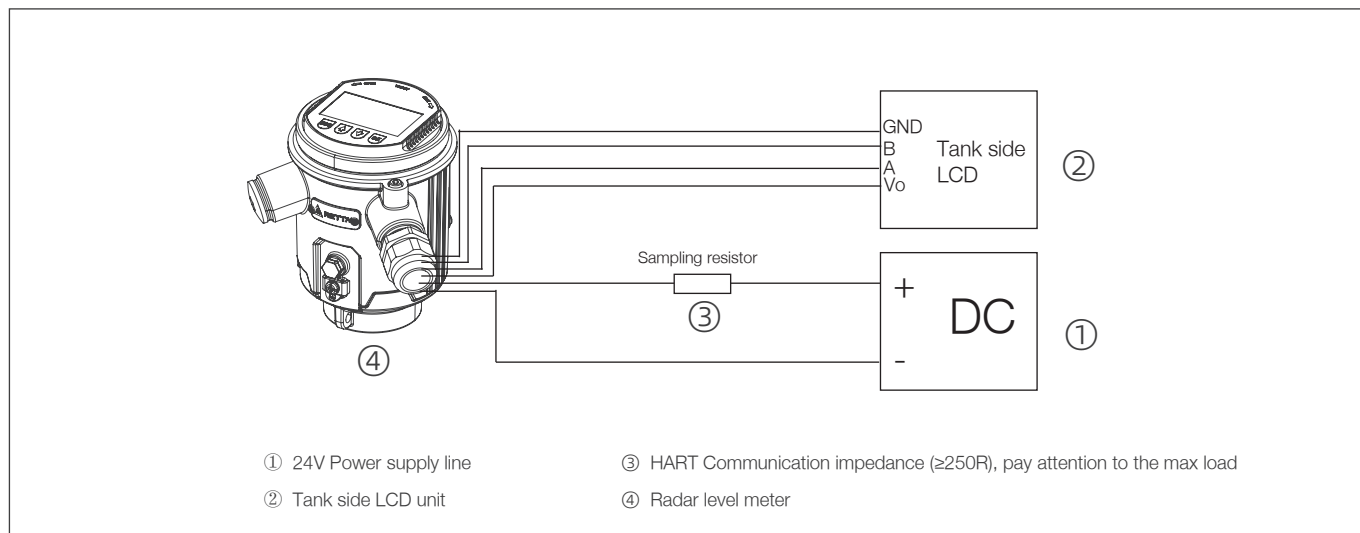

## 24V Single compartment two-wire positive tank side wiring diagram

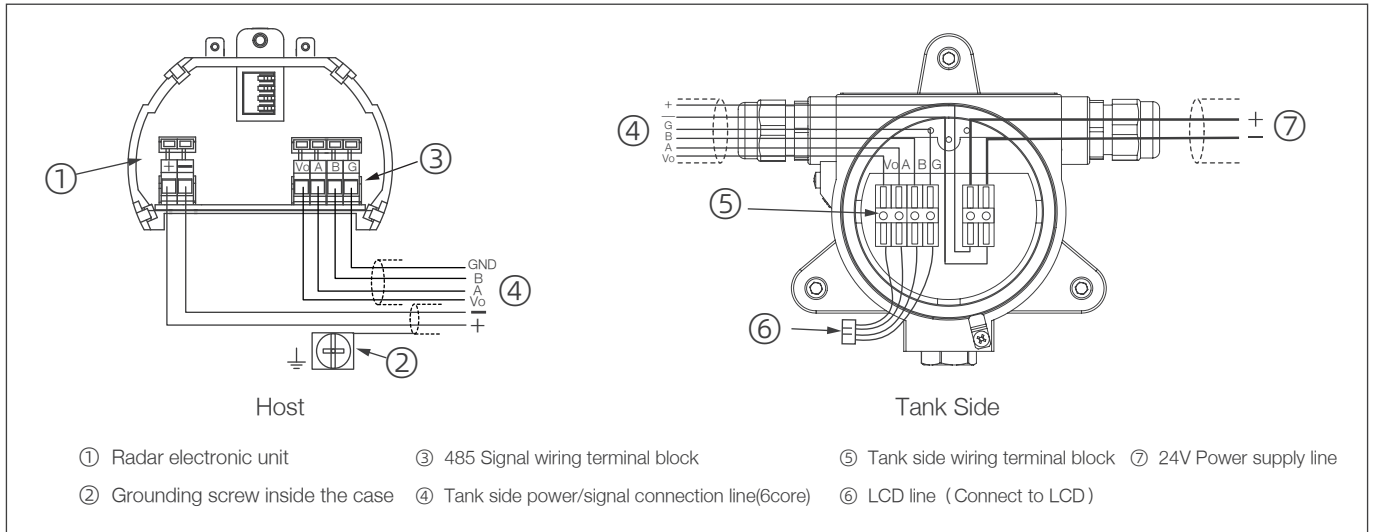

## 24V Single compartment two-wire Modbus output

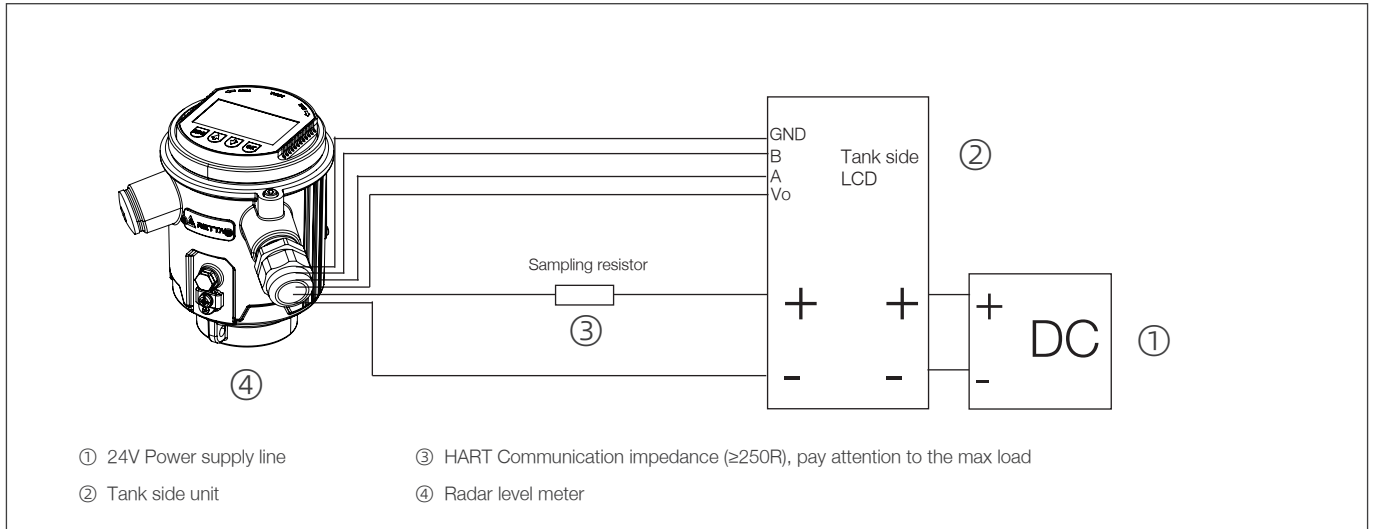

## 24V Dual compartment two-wire passive tank side wiring diagram

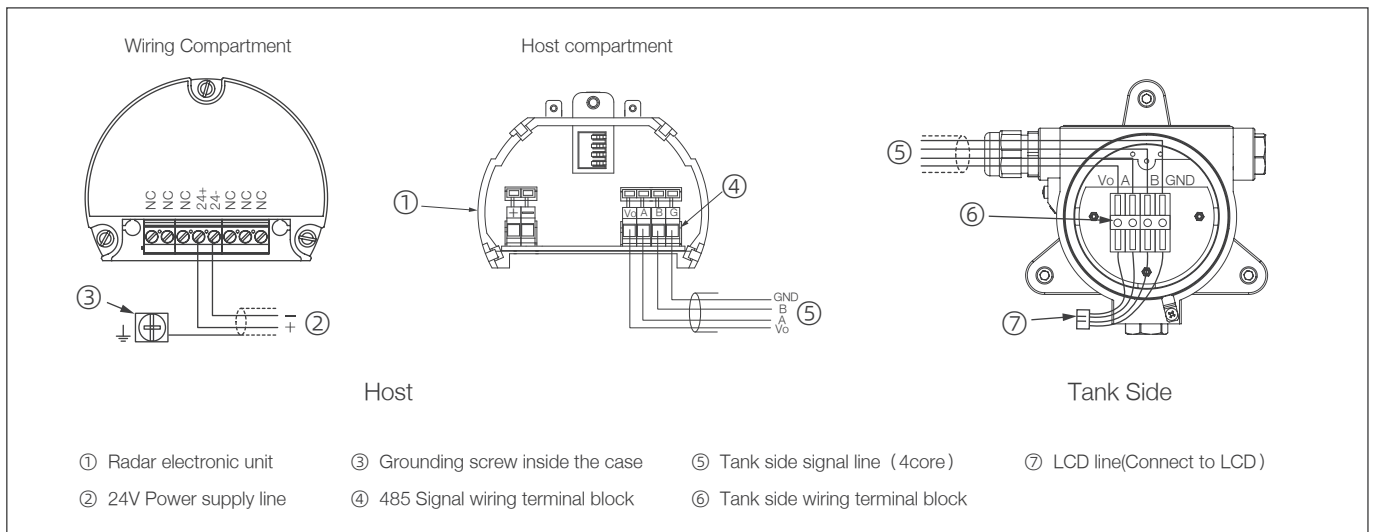

24V Dual compartment two-wire passive tank side 4...20mA HART

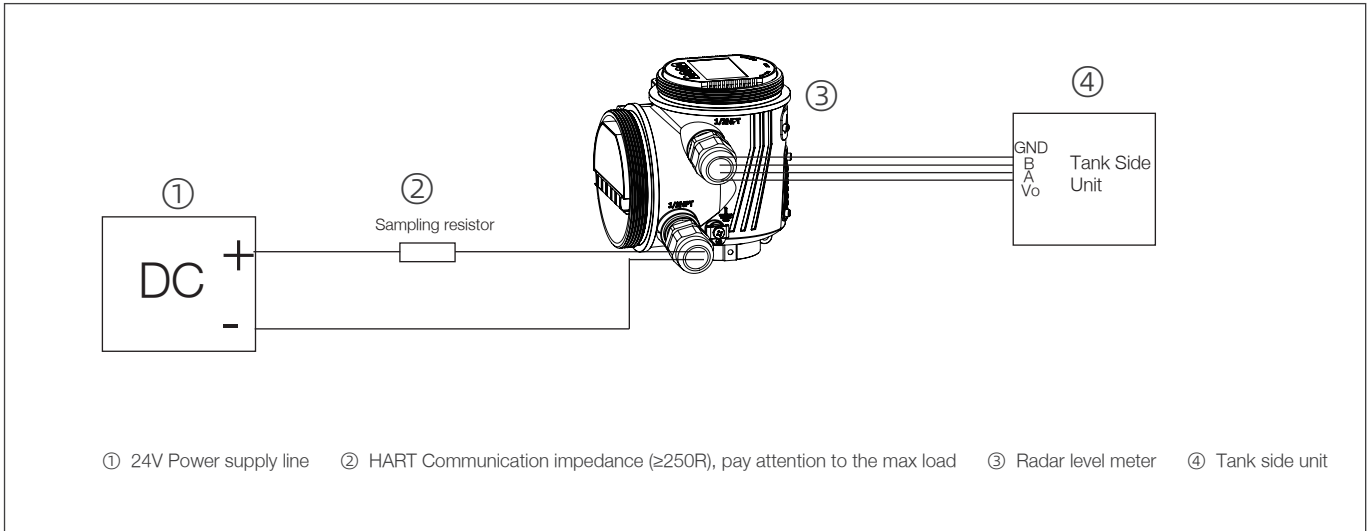

24V Dual compartment four-wire passive tank side wiring diagram

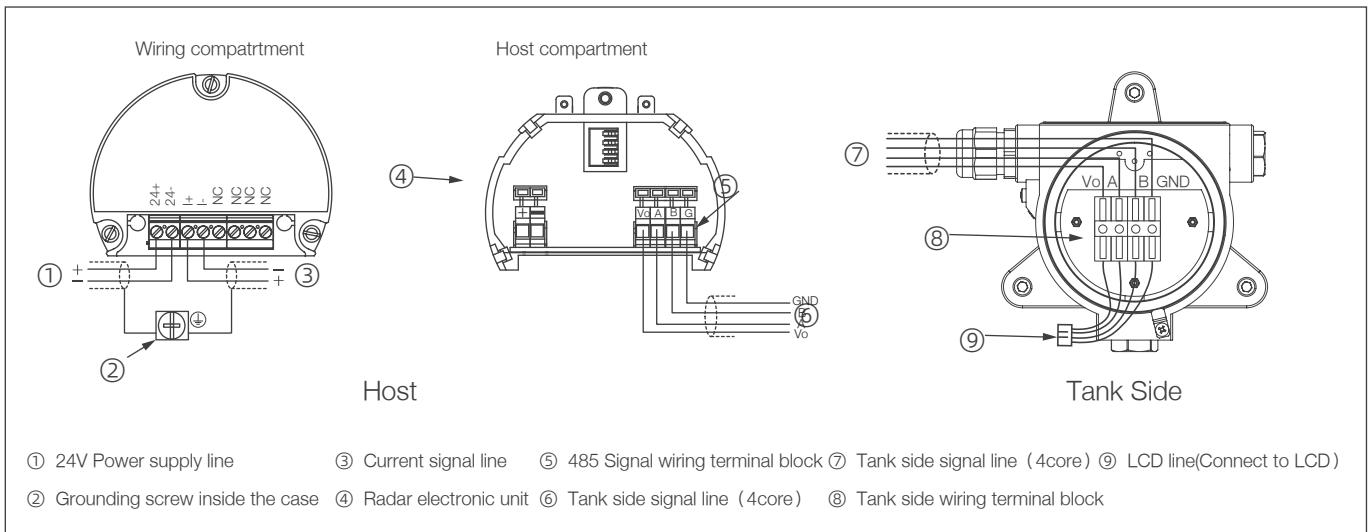

24V Dual compartment four-wire passive tank side 4...20mA HART

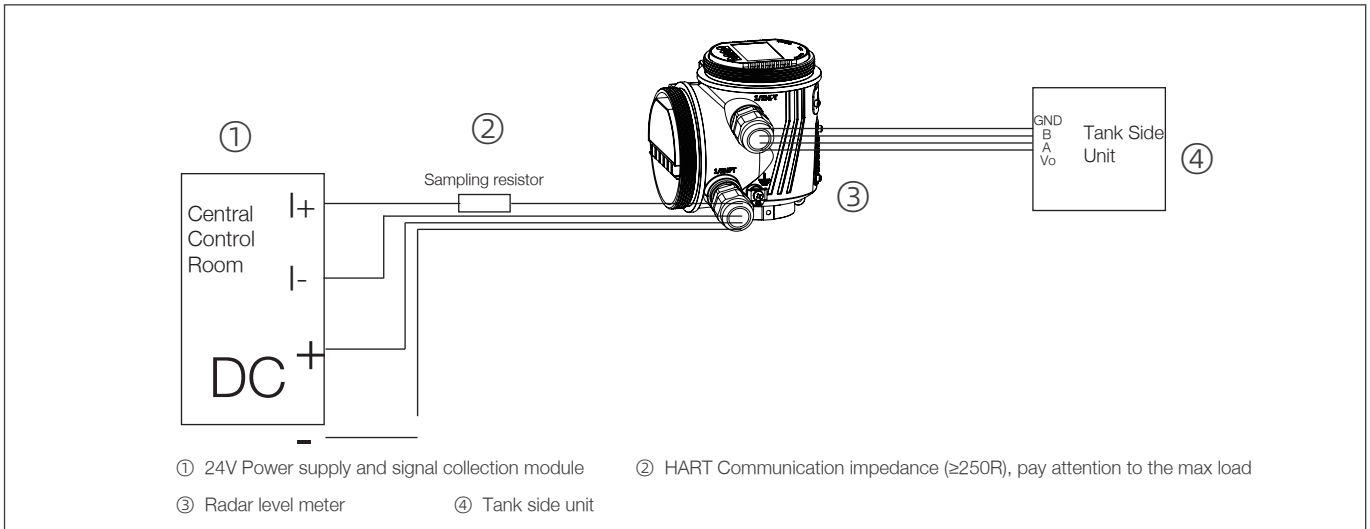

## 220V Dual compartment four-wire passive tank side wiring diagram

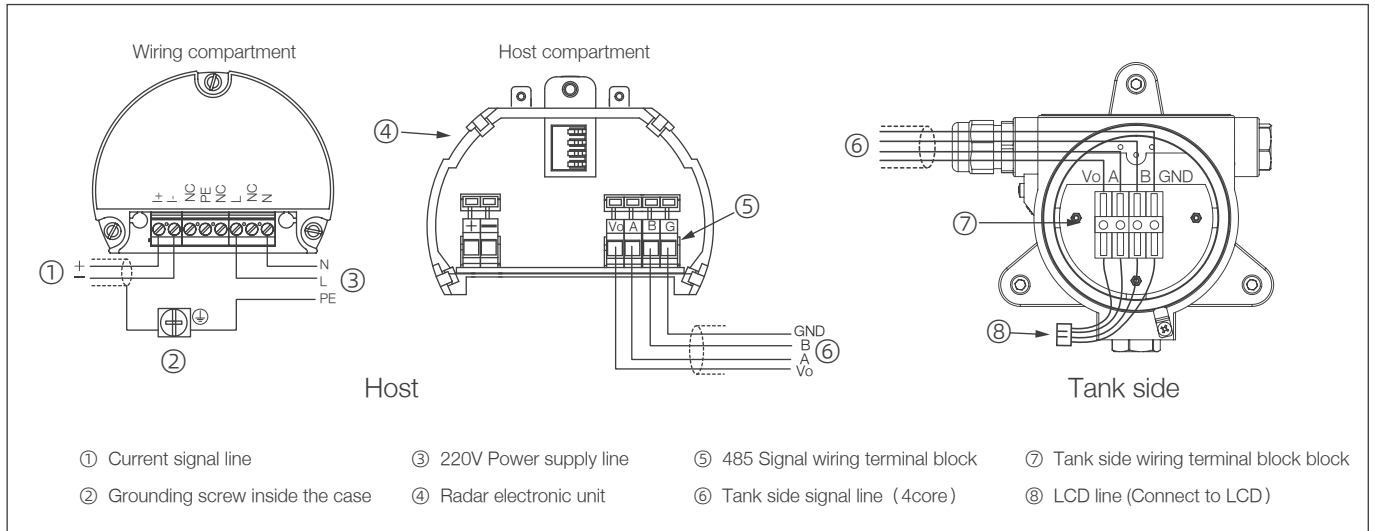

## 220 Dual compartment four-wire passive tank side 4...20mA HART

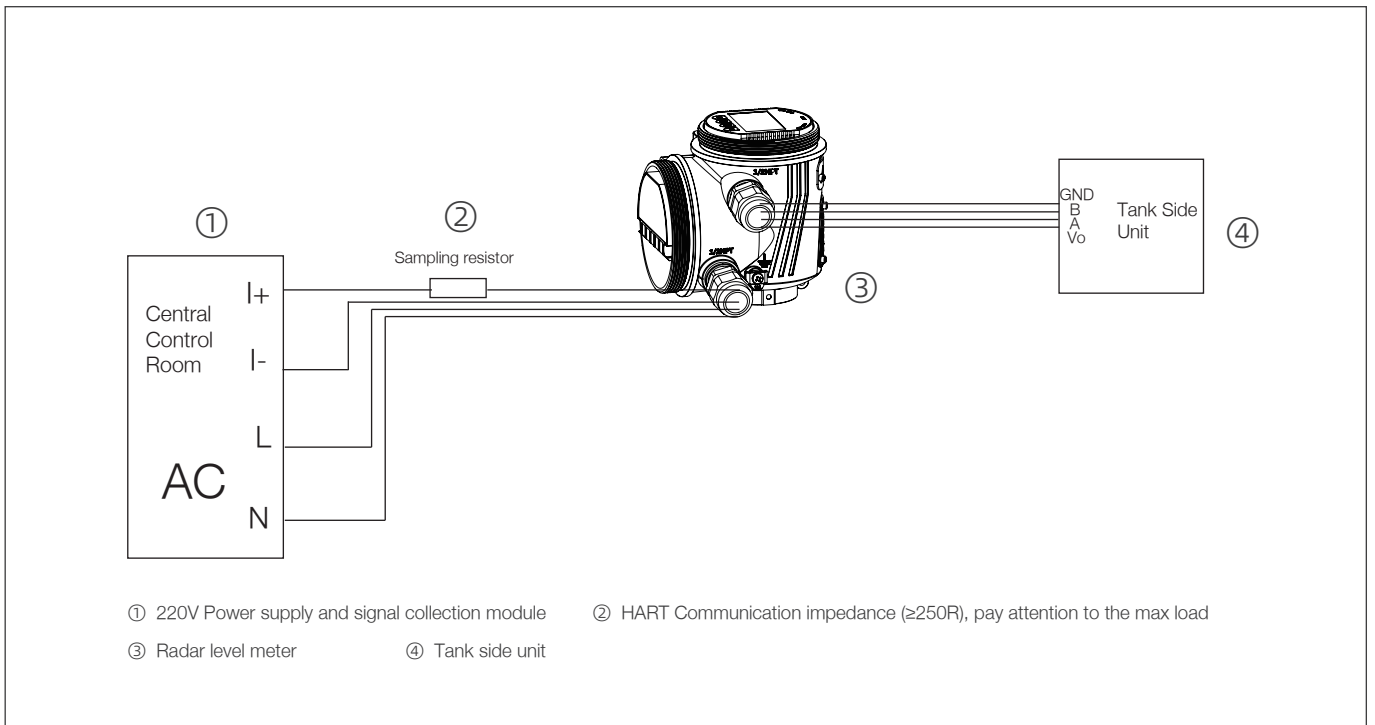

# Instrument Debugging

## Debugging on-site

(1) Through the LCD display module



(2) Using Bluetooth functionality on Android phone or tablet

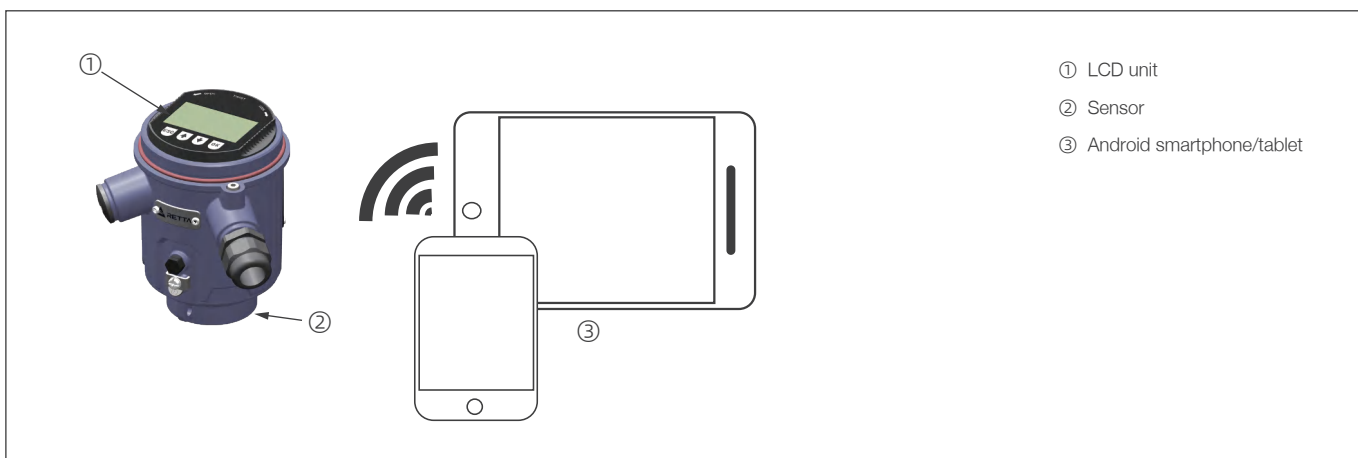

(3) Debugging through LEVELWARE software, connecting the instrument to the computer USB interface through RS485 communication interface.

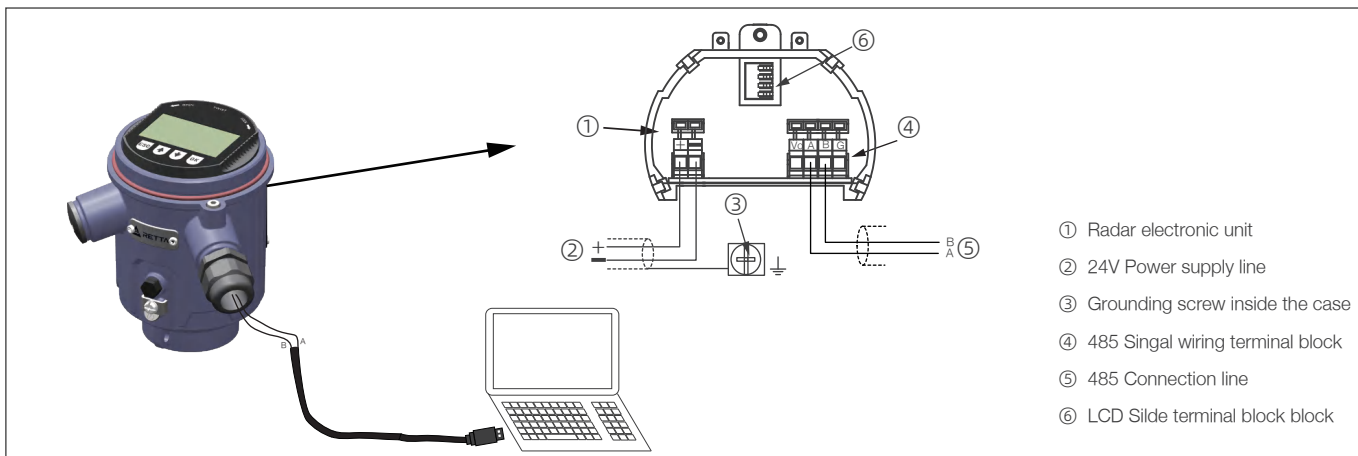

## (4) HART Communicator (LCD display unit in central control room)

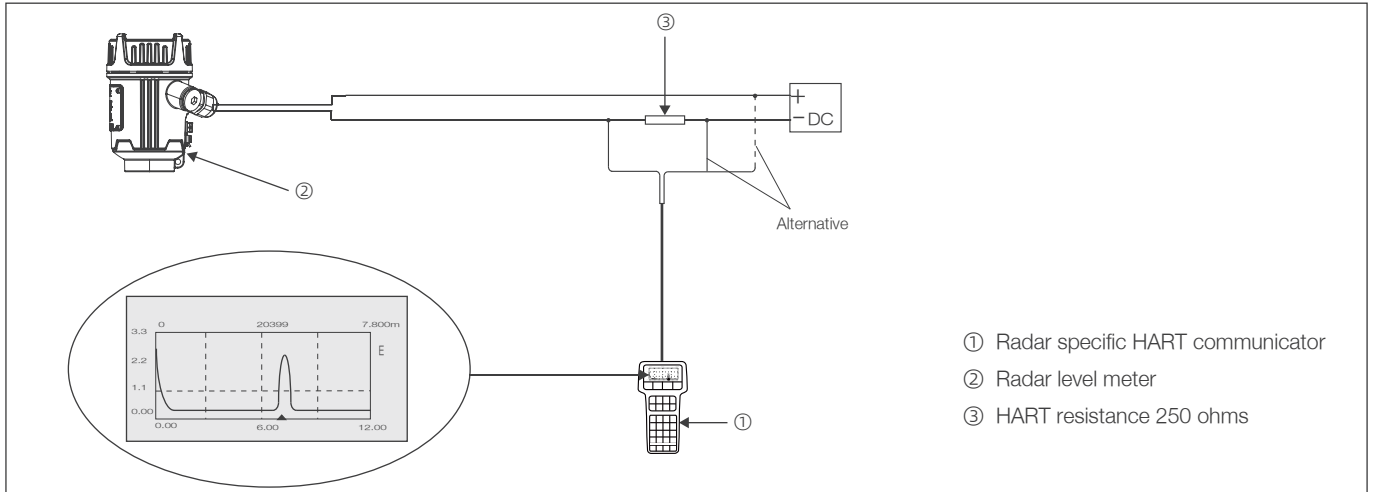

## Remote debugging

Remote display unit——positive tank side

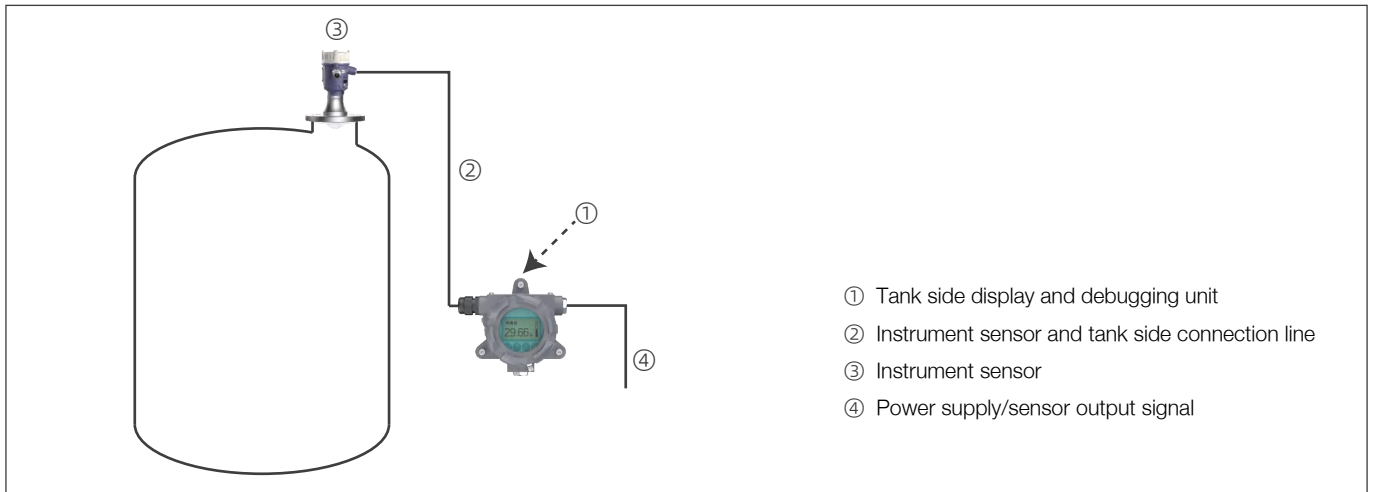

Remote display unit——passive tank side

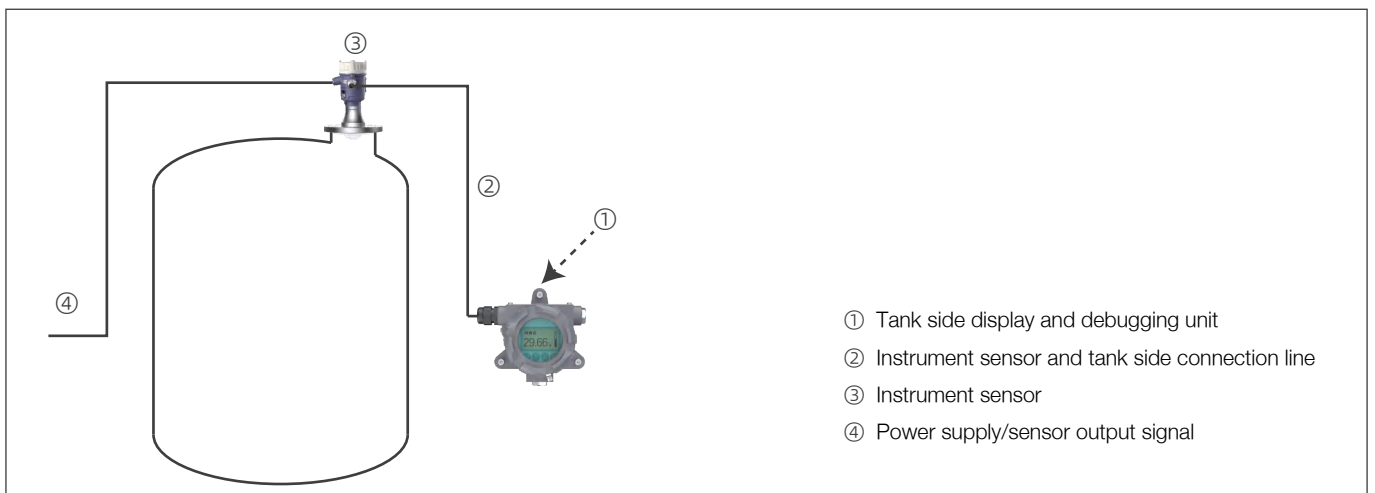

# Structure Size

Single compartment housing size (Note: The values marked in [ ] are in inches, and the rest are in millimeters)

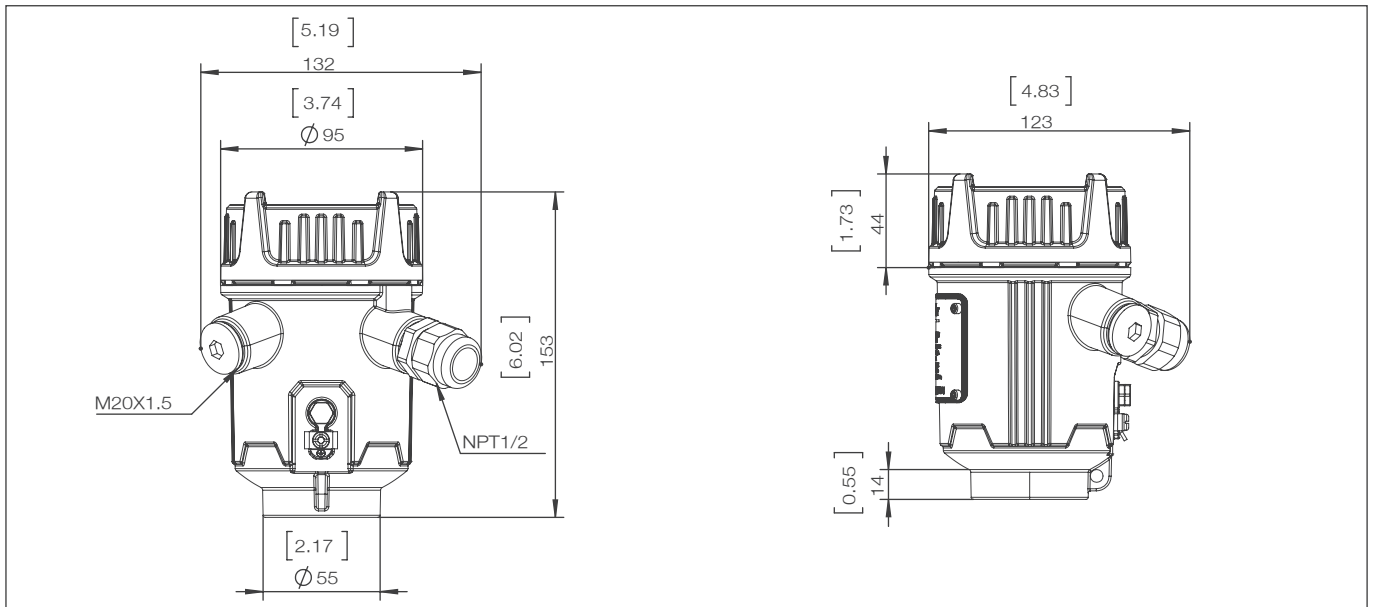

Dual compartment housing size (Note: The values marked in [ ] are in inches, and the rest are in millimeters)

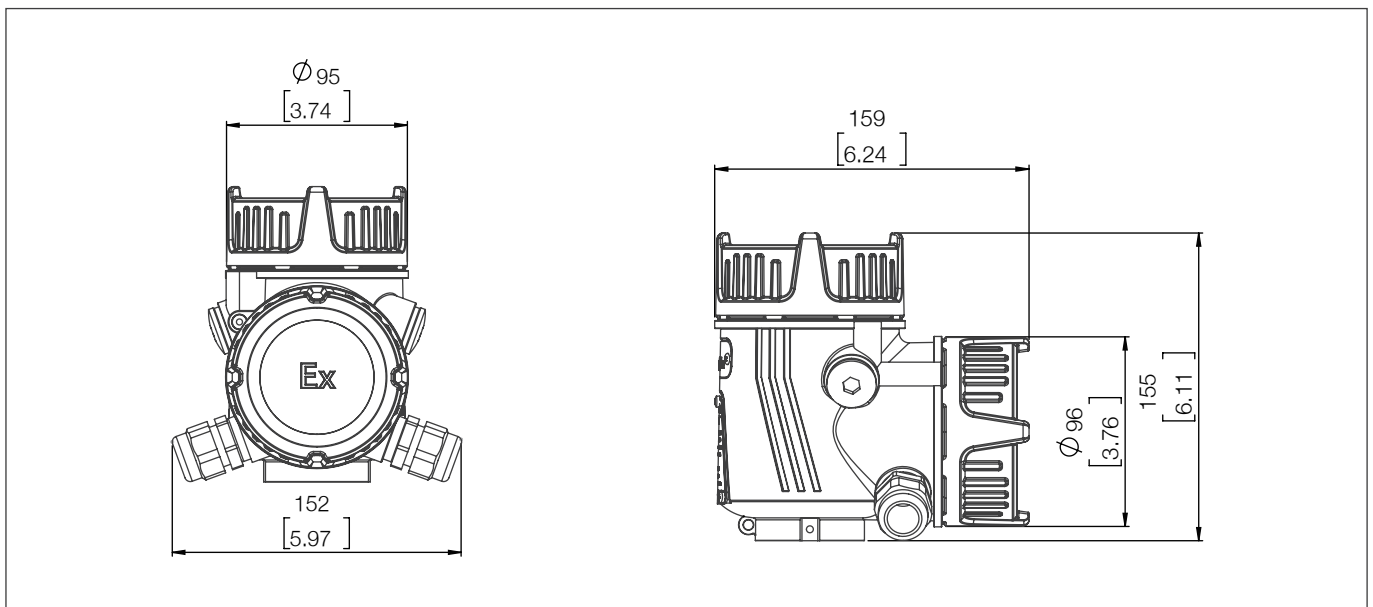

## Instrument Size (Note: The values marked in [ ] are in inches, and the rest are in millimeters)

### CPR6400 Radar Liquid Level Meter With Rod Antenna

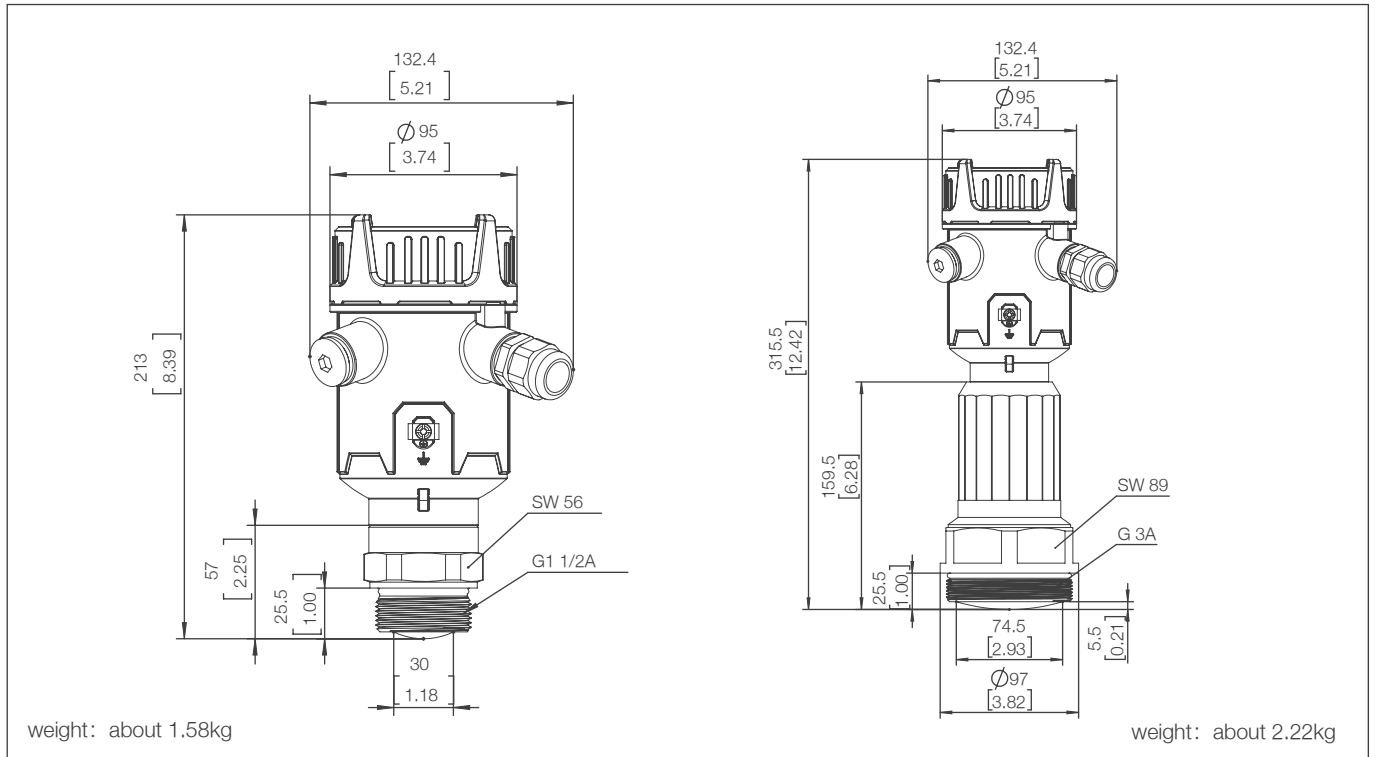

### CPR6400 Integrated Radar Liquid Level Meter

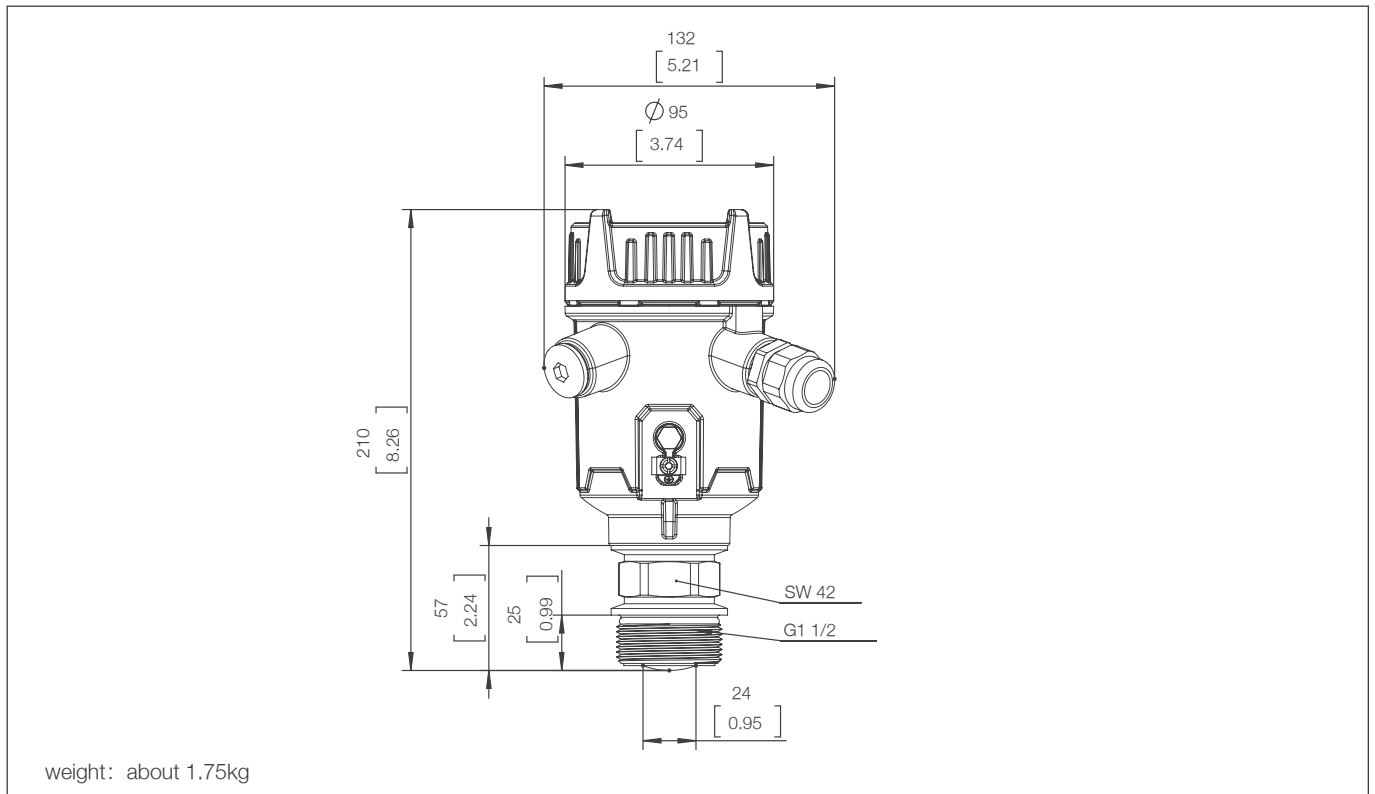

CPR6400 Radar Liquid Level Meter With Plastic Horn Antenna

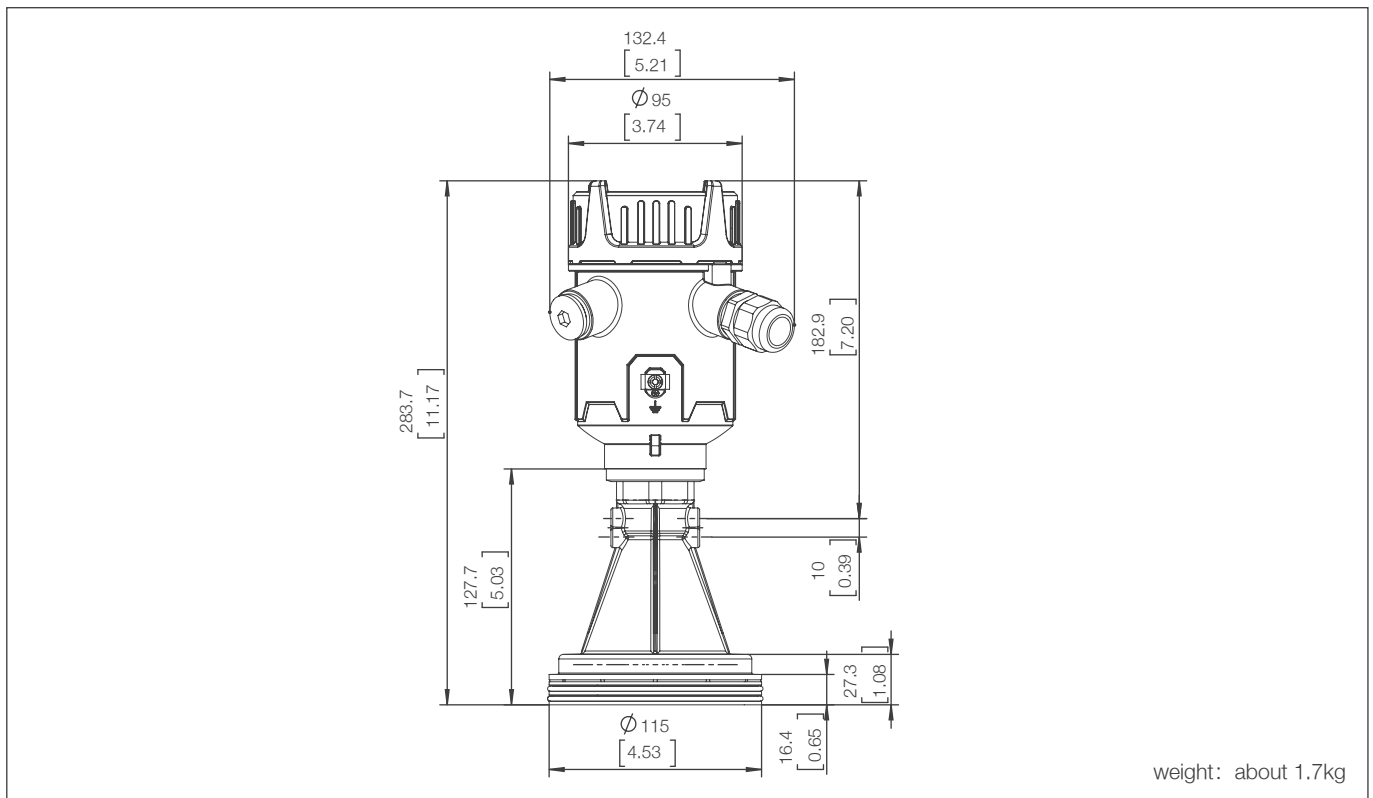

CPR6400 Radar Liquid Level Meter With Process Sealed Antenna

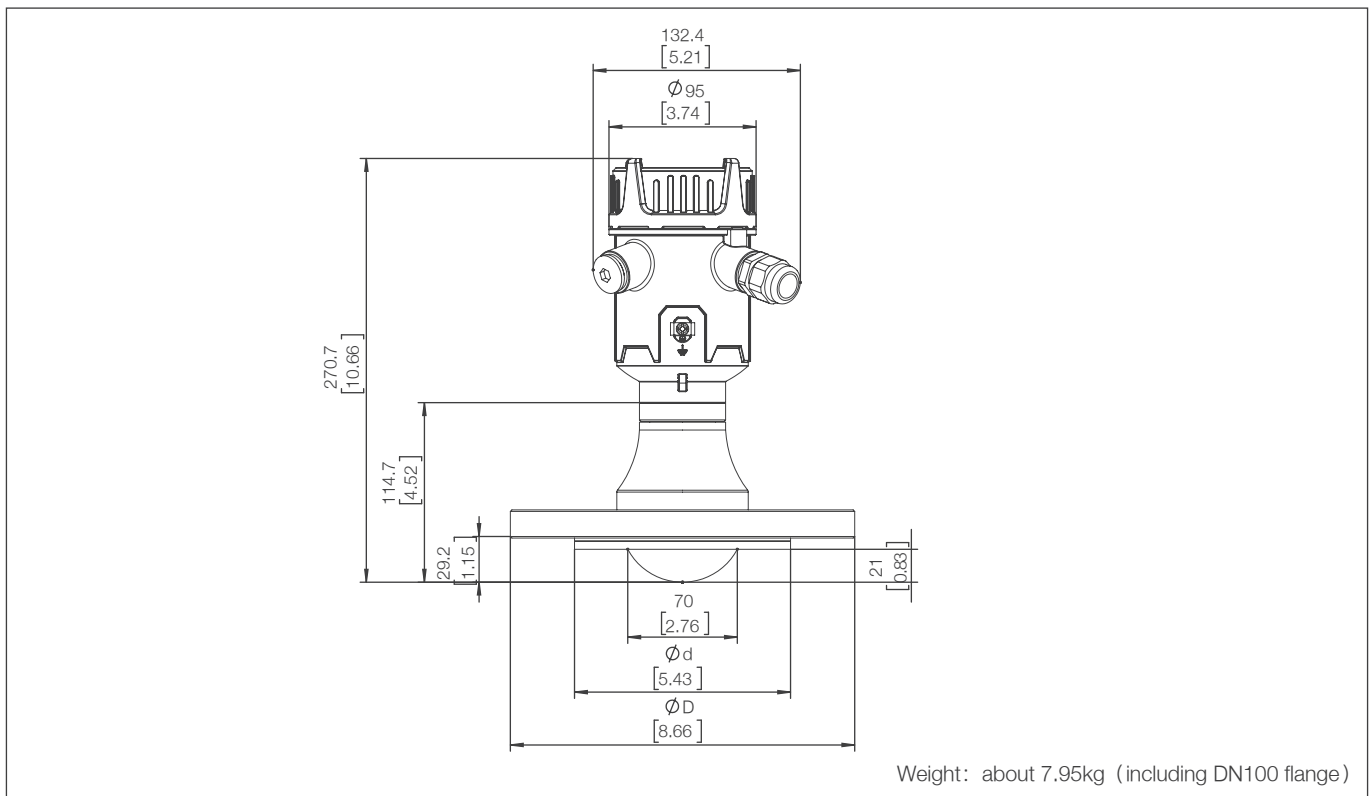

## CPR6400 Radar Liquid Level Meter With Hygienic Antenna

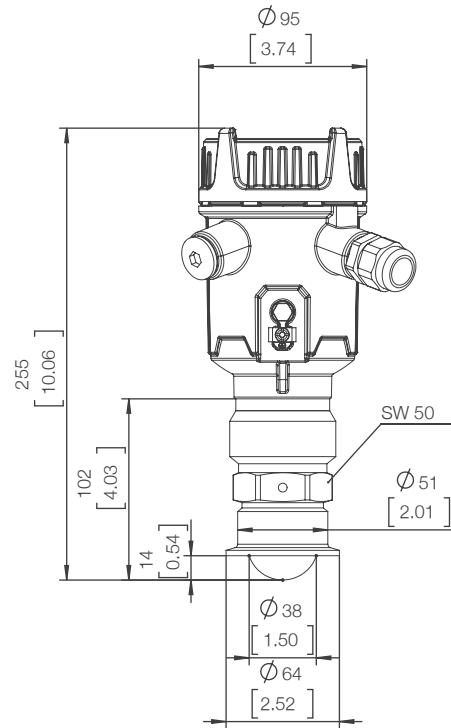

Weight: about 2.2kg

## CPR6900 Radar Solid Level Meter With Plastic Horn Antenna

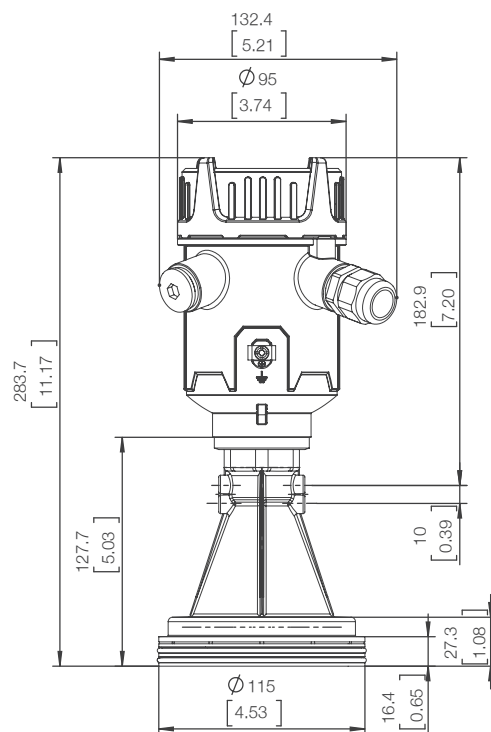

Weight: about 1.57kg

CPR6900 Integrated Radar Solid Level Meter

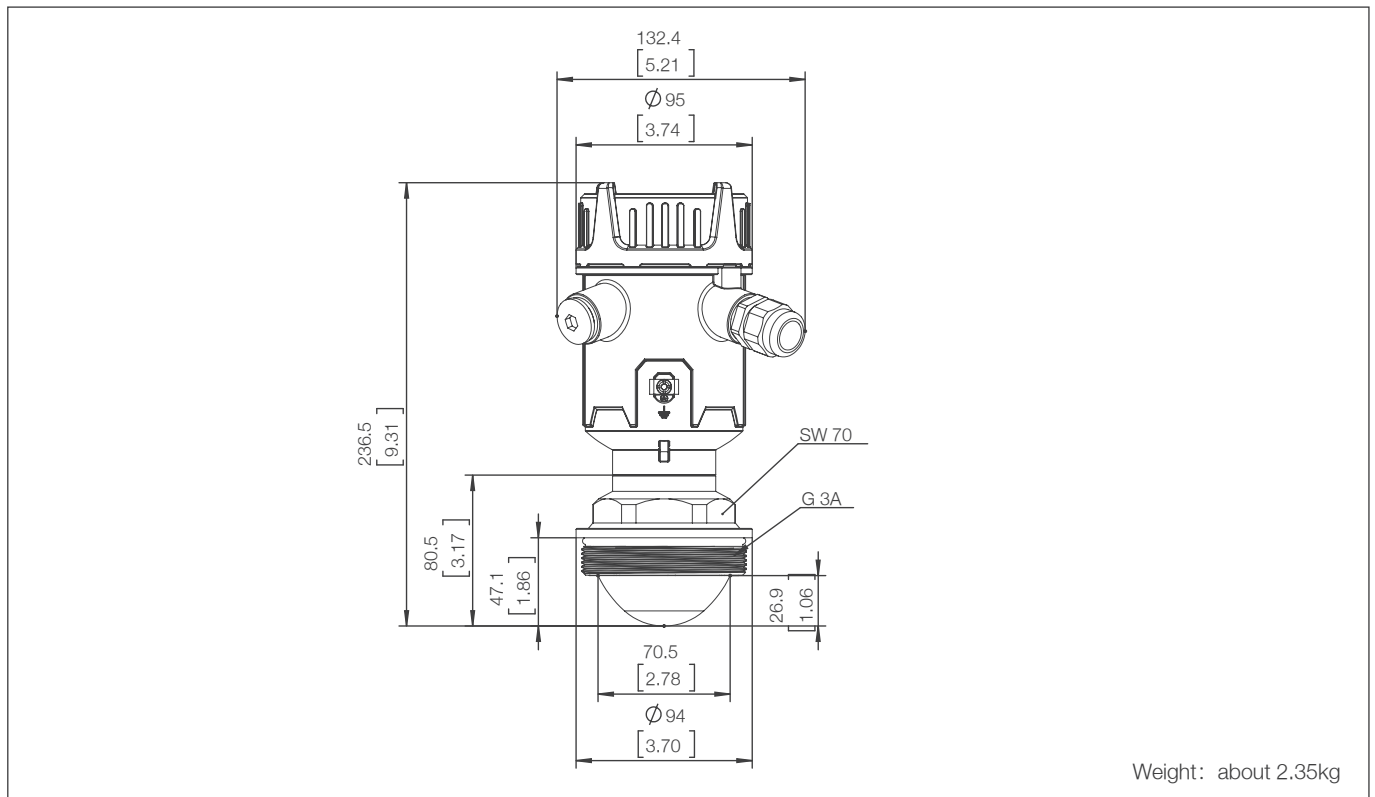

CPR6900 Radar Solid Level Meter With Rod Antenna

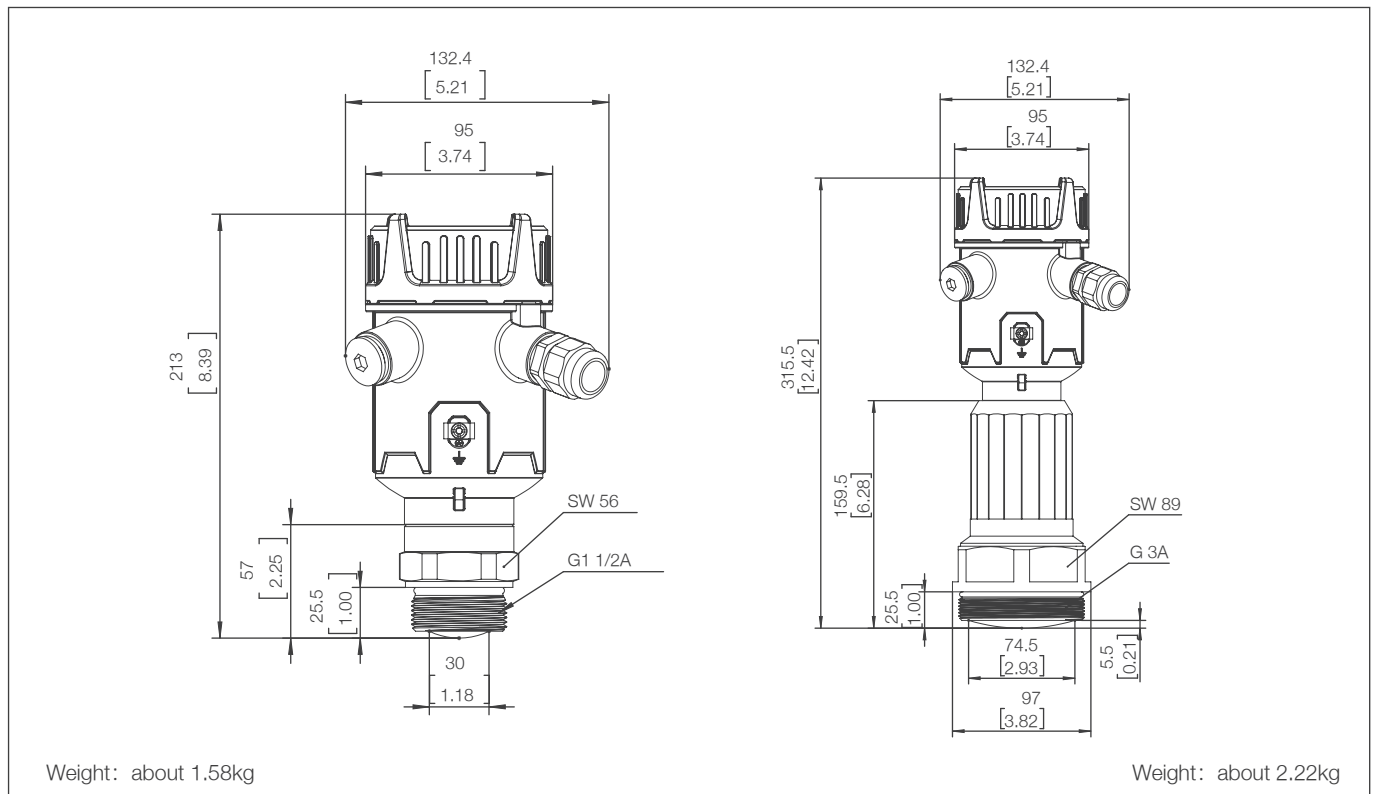

## CPR6900 Radar Solid Level Meter With Universal Joint Antenna

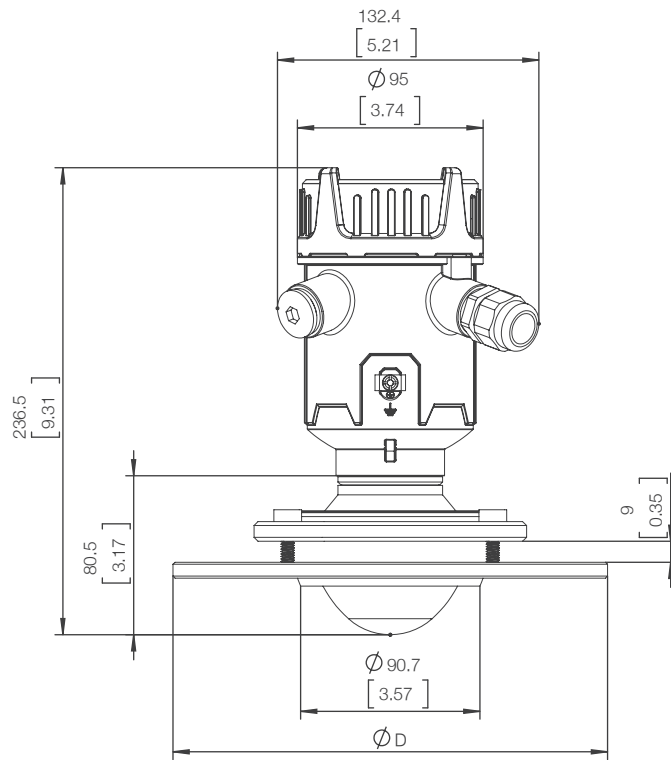

Weight: about 5.15kg (including DN100 bottom flange)

RETTAR

INDUSTRIAL MEASUREMENT INNOVATOR



☎ 400-801-0770

🌐 [www.rettar.com](http://www.rettar.com)

✉ [marketing@rettar.com](mailto:marketing@rettar.com)

📍 Lutong Hongyun Technology Park,  
No. 17 Yunshan South Road,  
Tongzhou District, Beijing