

# 26GHz Radar Level Meter

Assist in Digital Management of Industrial Materials

# Content

Company Profile_____	02	Housing Form_____	09
Company Qualifications____	03	Installation Requirements__	10
Measuring Principle_____	04	Electronic Components____	12
Product Advantages_____	05	Instrument Debugging_____	20
Instrument Profile_____	06	Structure Size_____	22



## Company Profile

RETTAR is an intelligent technology company that continuously achieves technological innovation in the field of industrial measurement with leading AI and radar technology. The company was founded in 2007, headquartered in Beijing, and originated from the Testing and Electronic Technology Research Institute of the Department of Automation at Tsinghua University. It has established a technology research and development center that serves global enterprises, owns 185 technology patents and intellectual property rights, and has obtained multiple international certifications.

The company focuses on automated measurement and control products such as radar level meters and 3D visual scanners, and has independently developed and produced nearly a hundred products to meet the needs of customers in various industrial measurement scenarios. Through the innovative technology of the R&D center, the company tailors customized solutions for customers and is a technological innovator in the field of industrial automation measurement and control in China.

RETTAR has a wide range of products, including 3D visual scanners, high-frequency radar level meters, micro-wave level meters, density meters, thermometers, interface meters, tank side controllers, and intelligent management systems. Now, RETTAR has cooperated with nearly 2000 domestic and foreign customers, and its products and solutions are widely used in fields such as oil and gas, electricity, metallurgy, chemical industry, building materials, coal, grain, feed, food and beverage, pharmaceuticals, environmental protection, mining, cement, etc.

# Company Qualifications



High Tech Enterprise Certificate



EU Trademark Certificate



Intellectual Property Pilot Unit



Invention Patent



Software Copyright



Product Measurement Certificate



ISO Certificate



Product Explosion Proof Certificate



Product Measurement Report



CE Certificate



Member of the HART/FF Foundation



TUV SIL Engineer Certificate

# Measuring Principle

Radar level meter is a wireless wave ranging system based on the principle of time travel. By transmitting a low-power microwave (radio wave with a frequency of 26GHz) pulse of less than 1mW through an antenna, this pulse propagates in space at the speed of light. The microwave pulse signal encounters the surface of the tested medium, and some of its energy is reflected back by the surface of the medium and received by the antenna. The time interval between the transmission and reception of microwave pulse signals is directly proportional to the distance from the antenna to the surface of the tested medium, and thus the distance from the antenna to the surface of the tested medium can be calculated.

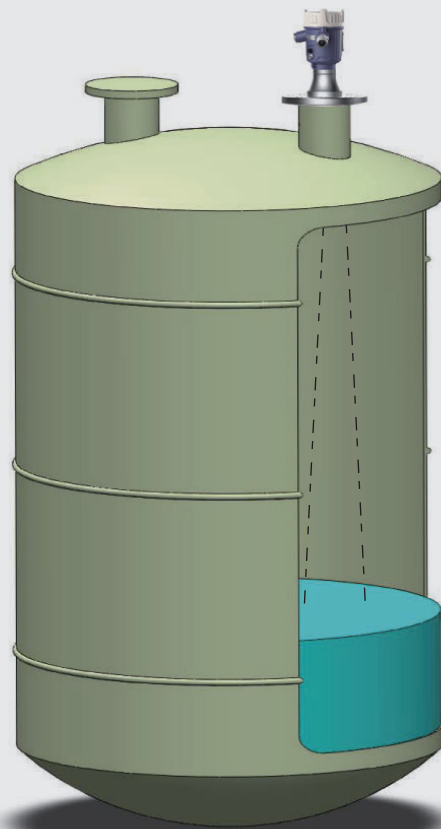

# Product Advantages

The dual CPU system radar level meter adopts a design system consistent with international first tier brands, greatly improving the hardware processing ability of the product, thereby improving the measurement performance, intelligence level, and product reliability of the instrument.

- ◆ The instrument adopts patented equivalent sampling pulse ranging technology, which not only improves the resolution and sensitivity of the signal, but also reduces the beam emission energy, and is harmless to humans. It can be installed in various metal and non-metallic containers or pipelines, with sensitive measurement and fast refresh speed.
- ◆ The instrument LCD display debugging unit is a 128 \* 64 graphics dot matrix LCD, which supports complex operations such as full Chinese menu, waveform display, and modification of false echoes. Reduce the difficulty of on-site instrument operation and maintenance workload.
- ◆ Not affected by pressure changes, vacuum, temperature changes, inert gases, smoke, steam, and other environmental factors, the measurement results are stable and reliable. Customization of instrument functions and sensors can be carried out based on the operational characteristics of domestic customer industries and on-site conditions.
- ◆ The LCD display unit can be connected to the outside for 25 meters, forming a display operation unit next to the tank. Reduce the risk and labor intensity of daily inspection work for instruments in high-risk areas such as large tanks, high temperature, high pressure, and toxicity.
- ◆ The waveform display function is a radar specific Hart communicator. By using the radar specific Hart communicator, it is possible to directly observe the radar waveform in the central control room and perform debugging, greatly reducing the danger and labor intensity of on-site debugging.
- ◆ The wireless communication function radar level meter can support GPRS wireless transmission and CMesh multi hop self-organizing wireless network transmission. It is the preferred product for level measurement and integration into the Internet of Things.
- ◆ RETTAR has launched a remote display operation unit based on Hart communication, which can be connected to an external 1000 meters, thus compensating for the shortcomings of traditional tank side display units in communication distance.
- ◆ Unique antenna type, more suitable for harsh on-site working conditions; Suitable for high-temperature working conditions, the specially customized high-temperature extended antenna can be used at a process temperature of 1000 °C.

# Instrument Profile



CPR6100 Radar Liquid Level Meter  
With Anti-corrosion Rod Antenna



CPR6200 Radar Liquid Level Meter  
With Horn Antenna

Application	Corrosive liquid in small containers with simple process conditions	Storage or process containers with complex process conditions
Measuring Range*	35m	70m
Antenna Form/Material	Rod antenna/PP、PTFE	Horn antenna/Stainless steel 316L
Contact Medium Material	PP/PTFE	Stainless steel 316L
Process Connection	Thread or flange/hygienic connection	Thread/flange connection
Process Temperature*	-40°C...+130°C	-60°C...+1000°C
Process Pressure*	-1...3bar	-1...40bar
Accuracy	±3mm	±3mm
Resolution Ratio	1mm	1mm
Response Time	< 2s	< 2s
Frequency Range	26GHz	26GHz
Signal Output	4...20mA/HART/RS485	4...20mA/HART/RS485
Display Debugging	LCD、Tank side monitor	LCD、Tank side monitor
Electrical Connection	M20*1.5、1/2 NPT (cable diameter 6~12mm)	M20*1.5、1/2 NPT (cable diameter 6~12mm)
Ingress Protection	IP67	IP67
ATEX	Ex ia IIC T2/T6 Ga Ex db ia [Ia Ga] IIC T6/T2 Gb	Ex ia IIC T2/T6 Ga Ex db ia [Ia Ga] IIC T6/T2 Gb



CPR6300 Radar Liquid Level Meter  
With Anti-corrosion Conical Antenna



CPR6700 Radar Solid Level Meter  
With Conical Antenna

Application	Corrosive medium with very complex process conditions	Measurement of block and particle solids
Measuring Range*	70m	15m
Antenna Form/material	Integrated conical antenna/PTFE	Plastic horn antenna/PP/PTFE
Contact Medium Material	PTFE	PP/PTFE
Process Connection	Flange/Hygienic connection	Gantry crane installation/Flange
Process Temperature*	-40°C...+130°C	-40°C...+80°C
Process Pressure*	-1...16bar	-1...2bar
Accuracy	±3mm	±3mm
Resolution Ratio	1mm	1mm
Response Time	< 2s	< 2s
Frequency Range	26GHz	26GHz
Signal Output	4...20mA/HART/RS485	4...20mA/HART/RS485
Display Debugging	LCD、Tank side monitor	LCD、Tank side monitor
Electrical Connection	M20*1.5、1/2 NPT (cable diameter 6~12mm)	M20*1.5、1/2 NPT (cable diameter 6~12mm)
Ingress Protection	IP67	IP67
ATEX	Ex ia IIC T2/T6 Ga Ex db ia [ia Ga] IIC T6/T2 Gb	Ex ia IIC T2/T6 Ga Ex db ia [ia Ga] IIC T6/T2 Gb



CPR6800 Radar Solid Level Meter  
With Parabolic Antenna

Application	Measurement of block, powder and particle solids
Measuring Range*	70m
Antenna Form/material	Horn/Parabolic antenna/Stainless steel 316L
Contact Medium Material	Stainless steel 316L
Process Connection	Flange connection
Process Temperature*	-60°C...+1000°C
Process Pressure*	-1...3bar
Accuracy	±3mm
Resolution Ratio	1mm
Response Time	< 2s
Frequency Range	26GHz
Signal Output	4...20mA/HART/RS485
Display Debugging	LCD、 Tank side monitor
Electrical Connection	M20*1.5、 1/2 NPT ( cable diameter 6~12mm )
Ingress Protection	IP67
ATEX	Ex ia IIC T2/T6 Ga Ex db ia [ia Ga] IIC T6/T2 Gb

## Specification

1、 The actual measurement range of the instrument depends on antenna size, medium reflectivity, instrument installation location, and possible interference reflections. ± 2mm is the instrument laboratory accuracy under standard conditions.

2、 \*Process temperature、 \*Process pressure、 \*Actual measuring distance are influenced by the on-site measurement, and operating conditions.

# Housing Form



Type	Single compartment	Dual compartment
Material	Aluminium alloy/Stainless steel	Aluminium alloy/Stainless steel
Surface Material	Surface powder-coated	Surface powder-coated
Seal Ring Material Quality	Silicon rubber	Silicon rubber
Instrument Window	Tempered glass	Tempered glass
Ingress Protection	IP67	IP67
Application	Industrial environment	Industrial environment

# Installation Requirements

(1) If measuring liquids, it is best to choose an opening at a radius of 1/2 of the tank body. Choose a location for easy installation and wiring, and make it convenient for future disassembly and assembly. The distance between the instrument and the tank wall must be no less than the larger of 200mm and 1/5 of the tank height.

(2) If measuring solids, it is best to choose the larger of the opening placed away from the feeding port, 500mm away from the tank wall, and 1/10 of the tank height.

(3) There should be no obstacles within the beam angle of the antenna microwave transmission beam, so installation should avoid facilities inside the tank as much as possible, such as ladders, limit switches, heating equipments, brackets, etc. If it cannot be avoided, a "level confirm" is required during installation.

(4) The microwave beam emitted by the antenna needs to be far away from the feed stream. The highest material level of the tested material is lower than the blind spot of the instrument measurement (usually at the end of the antenna, and the low dielectric constant or blind spot of solid materials should be appropriately increased). The distance between the end of the antenna and the surface of the medium should be at least 100mm to ensure that the material does not contaminate the antenna.

(5) For liquid measurement, the installation of the instrument must ensure that the antenna is perpendicular to the surface of the measured medium. For solid state measurement, try to ensure that the antenna is perpendicular to the surface of the measured medium.

(6) Instruments installed in explosion-proof areas must comply with the national installation regulations for explosion-proof hazardous areas.

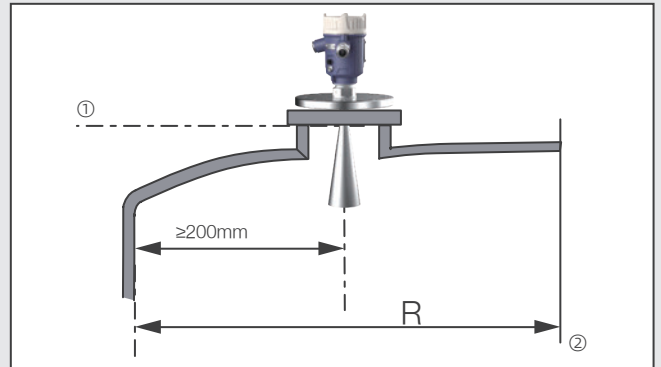

① Measuring datum plane ② Container center or axis of symmetry

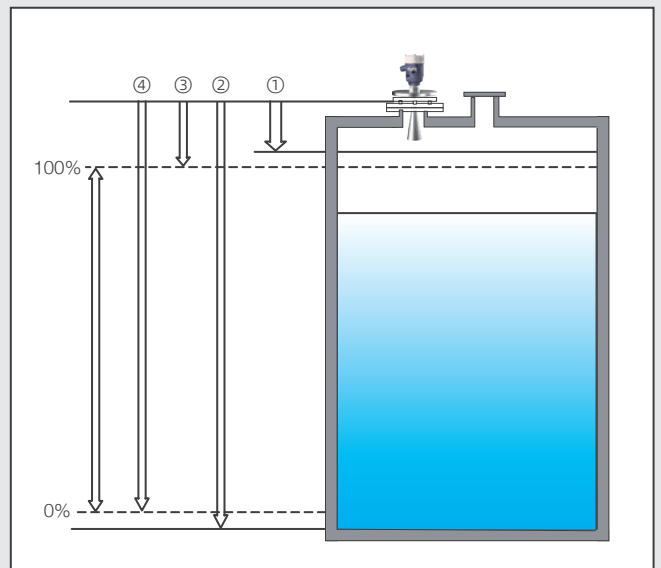

① High blind zone ② Low blind zone ③ High range ④ Low range



When using radar, it is important to ensure that the highest material level does not enter the measurement blind zone.

## Installation Example



① Installation of Small Tank/Flange

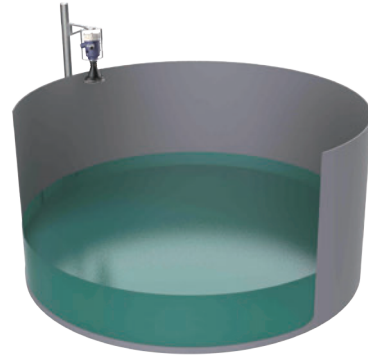

② Installation of Open Pool/Gantry Crane



③ Installation of Reactor/Flange



④ Installation of Large Solid Silo/Flange/Thread

# Electronic Components

The CPR6X00 series radar level meter adopts detachable electronic components for easy on-site replacement.

## (1) Two-wire system 4...20mA/HART

Supply Voltage: 20-28VDC

Connecting Cable: 4...20mA/HART(Two -wire system)

The instrument power supply and current signal share a two core cable.

The cable should be shielded with an outer diameter between 6-12mm. Ensure the sealing of the cable entry, and it is recommended to use standard two core cables for wiring. The recommended cable model is Belden3076F. For intrinsically safe types, a safety barrier must be added between the power supply and the instrument.

Shielded cables and grounding:

- ◆ Both ends of the shielded cable should be grounded.
- ◆ The grounding terminal inside the instrument housing is used for cable shielding or grounding of a dedicated grounding wire.
- ◆ The external grounding terminal of the instrument housing is used to complete the grounding between the instrument and the on-site ground.
- ◆ If there is grounding current, the shielding end of the shielded cable on the side away from the instrument must be grounded through a ceramic capacitor (such as InF1500V) to suppress low-frequency grounding current while still preventing high-frequency interference signals.

### Single compartment two-wire housing (24V)

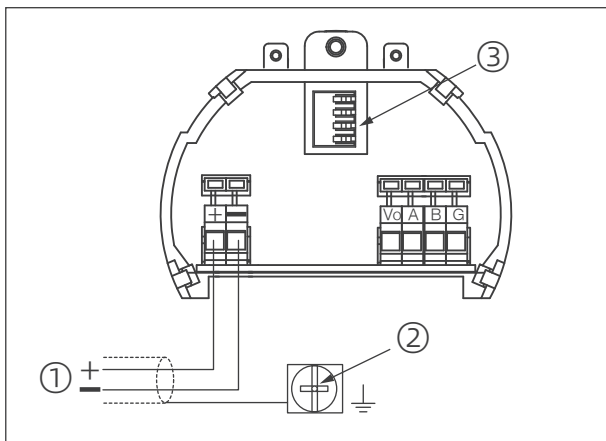

Diagram: Wiring compartment for single compartment two -wire housing

- ① 24V Power supply line
- ② Grounding screw inside the case
- ③ LCD connection module

### Single compartment two-wire 4...20mA HART (24V)

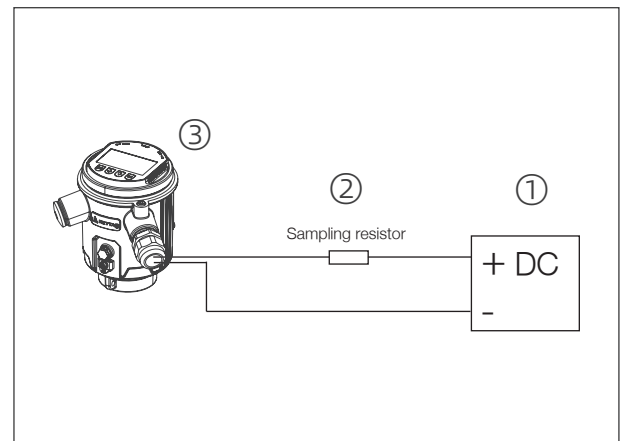

Diagram: Wiring compartment for single compartment two -wire housing

- ① 24V Power supply line
- ② HART Communication impedance ( $\geq 250\Omega$ ), pay attention to the max load
- ③ Radar level meter

## Dual compartment two-wire housing (24V)

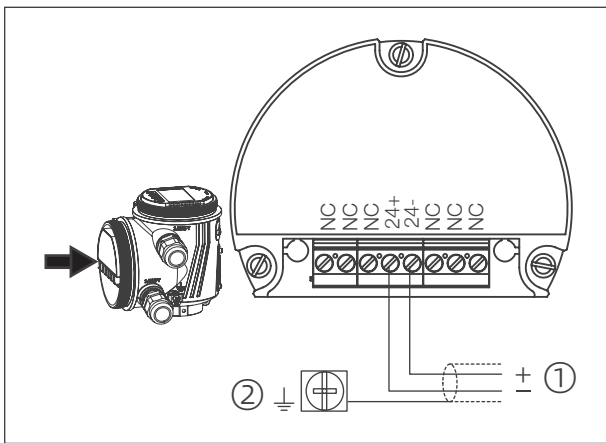

Diagram: Wiring compartment for dual compartment two -wire housing

- ① 24V Power supply line
- ② Grounding screw inside the case

## Dual compartment two-wire 4...20mA HART (24V)

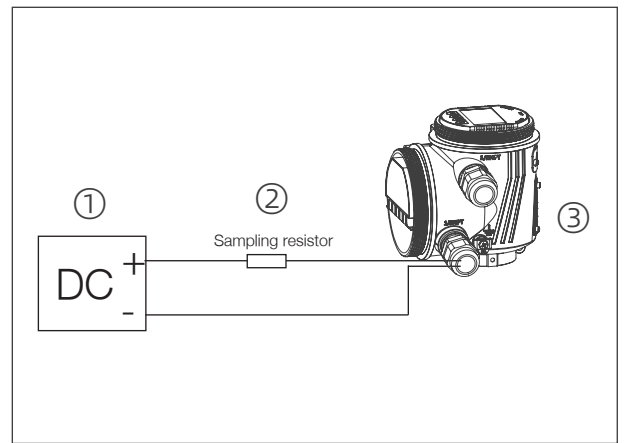

Diagram: Wiring compartment for dual compartment two -wire housing

- ① 24V Power supply line
- ② HART Communication impedance ( $\geq 250\Omega$ ), pay attention to the max load
- ③ Radar Level Meter

## (2) Four-wire system 4...20mA/HART

Supply Voltage: 220VAC or 20-28VDC

Connecting cable: 4...20mA/HART (four-wire system) The instrument power supply and current signal each use a two core cable.

The cable should be shielded with an outer diameter between 6-12mm. Cables should use cables with dedicated ground wires.

Shielded cables and grounding:

- ◆ Both ends of the shielded cable should be grounded.
- ◆ The grounding terminal inside the instrument housing is used for cable shielding or grounding of a dedicated grounding wire.
- ◆ The external grounding terminal of the instrument housing is used to complete grounding between the instrument and the on-site ground.
- ◆ If there is grounding current, the shielding end of the shielded cable on the side away from the instrument must be grounded through a ceramic capacitor (such as 1nF1500V) to suppress low-frequency grounding current while still preventing high-frequency interference signals.

Dual compartment four-wire housing (24V)

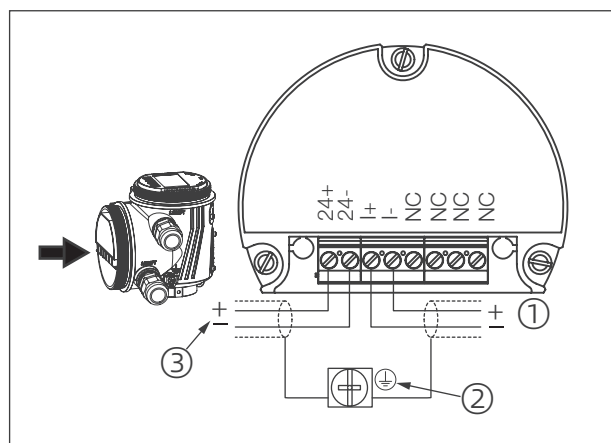

Diagram: Wiring compartment for dual compartment four -wire housing

- ① Current signal line
- ② Grounding screw inside the case
- ③ 24V Power supply line

Dual compartment four-wire 4...20mA HART (24V)

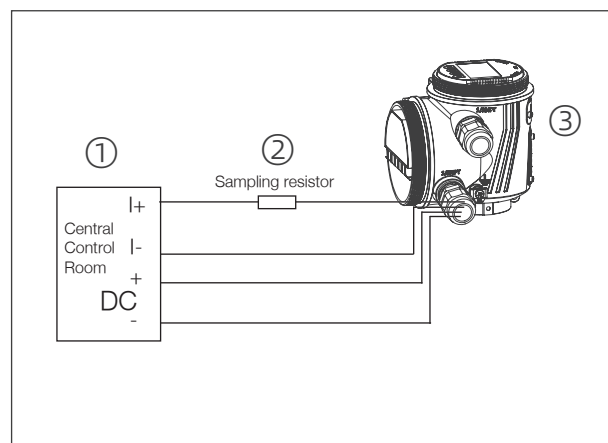

Diagram: Wiring compartment for dual compartment four -wire housing

- ① 24V Power supply and signal collection module
- ② HART Communication impedance ( $\geq 250R$ ), pay attention to the max load
- ③ Radar level meter

Dual compartment four-wire housing (220V)

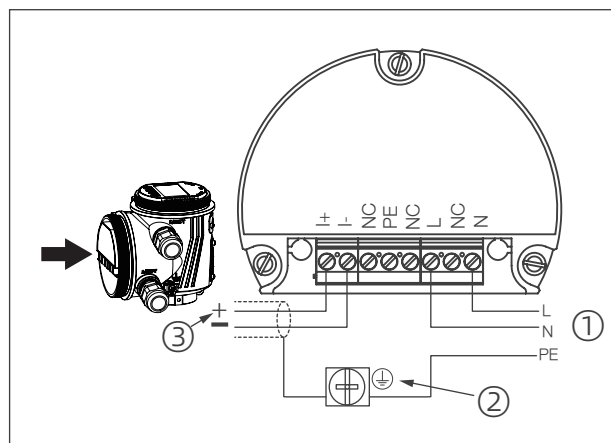

Diagram: Wiring compartment for dual compartment four -wire housing

- ① Current signal line
- ② Grounding screw inside the case
- ③ 220V Power supply line

Note: If the current signal is not connected to the central control room on site, it is necessary to short circuit I+and I- with wires!

Dual compartment four-wire 4...20mA HART (220V)

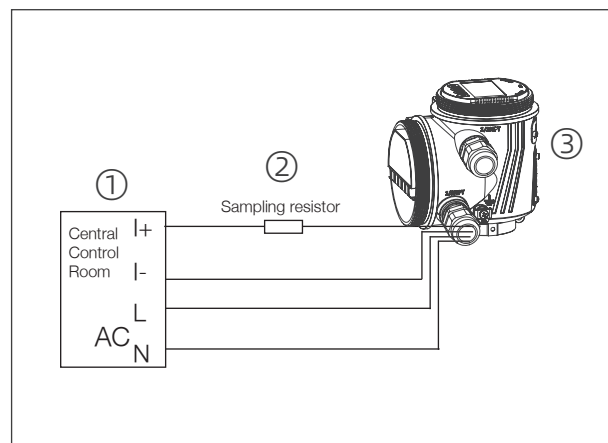

Diagram: Wiring compartment for dual compartment four -wire housing

- ① 220V Power supply and signal collection module
- ② HART Communication impedance ( $\geq 250R$ ), pay attention to the max load
- ③ Radar level meter

## (3) RS485 (Non-Isolated)

Output method: Modbus-RTU

Supply voltage: 20-28VDC

Connecting Cable:

- ◆ The power supply cable uses a separate two core cable
- ◆ RS485 requires the twisted pair cables suitable for RS485 communication for connection. If the on-site electromagnetic interference exceeds the standard of EN61326-1, shielded twisted pair cables are required.
- ◆ If multiple radars are connected to an RS485 line, the end of the radar needs to be connected in parallel with a 120ohm resistor.

Shielded cables and grounding:

- ◆ Both ends of the shielded cable should be grounded.
- ◆ The grounding terminal inside the instrument housing is used for cable shielding or grounding of a dedicated grounding wire.
- ◆ The external grounding terminal of the instrument housing is used to complete the grounding between the instrument and the on-site ground.
- ◆ If there is grounding current, the shielding end of the shielded cable on the side away from the instrument must be grounded through a ceramic capacitor (such as InF1500V) to suppress low-frequency grounding current while still preventing high-frequency interference signals.

Modbus Wiring diagram

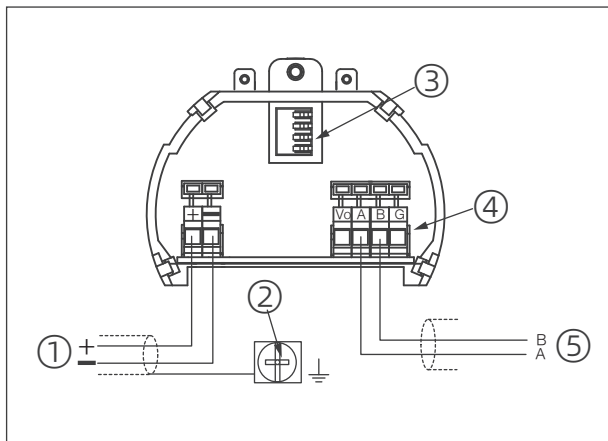

Diagram: Modbus wiring

- ① 24V Power supply line
- ② Grounding screw inside the case
- ③ LCD slider terminal
- ④ 485 Signal wiring terminal
- ⑤ 485 Signal line (2-core)

Two-wire system: Modbus Output

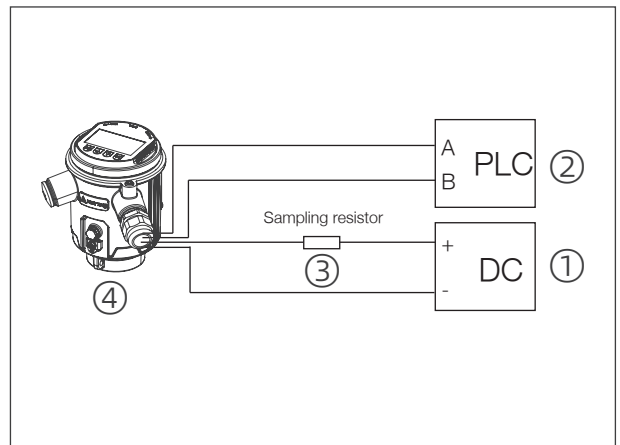
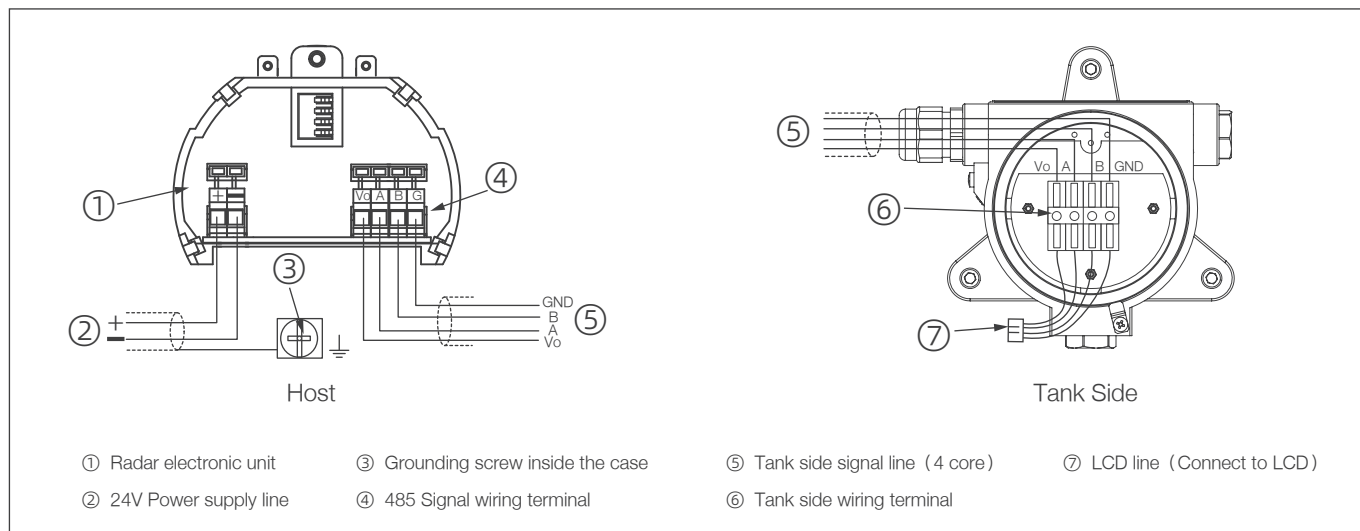

Diagram: Two-wire system Modbus output

- ① 24V Power supply line
- ② PLC
- ③ HART Communication impedance ( $\geq 250\Omega$ ), pay attention to the max load
- ④ Radar level meter

(4) Remote display unit

24V Single compartment two-wire passive tank side wiring diagram



24V Single compartment two-wire system Modbus output

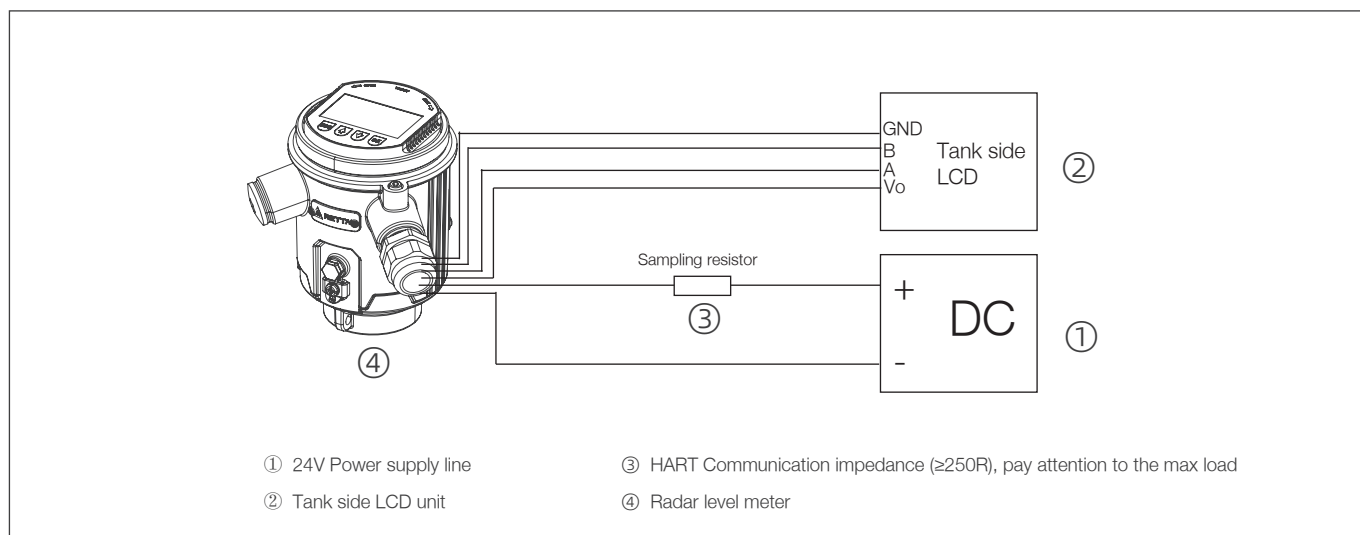

## 24V Single compartment two-wire positive tank side wiring diagram

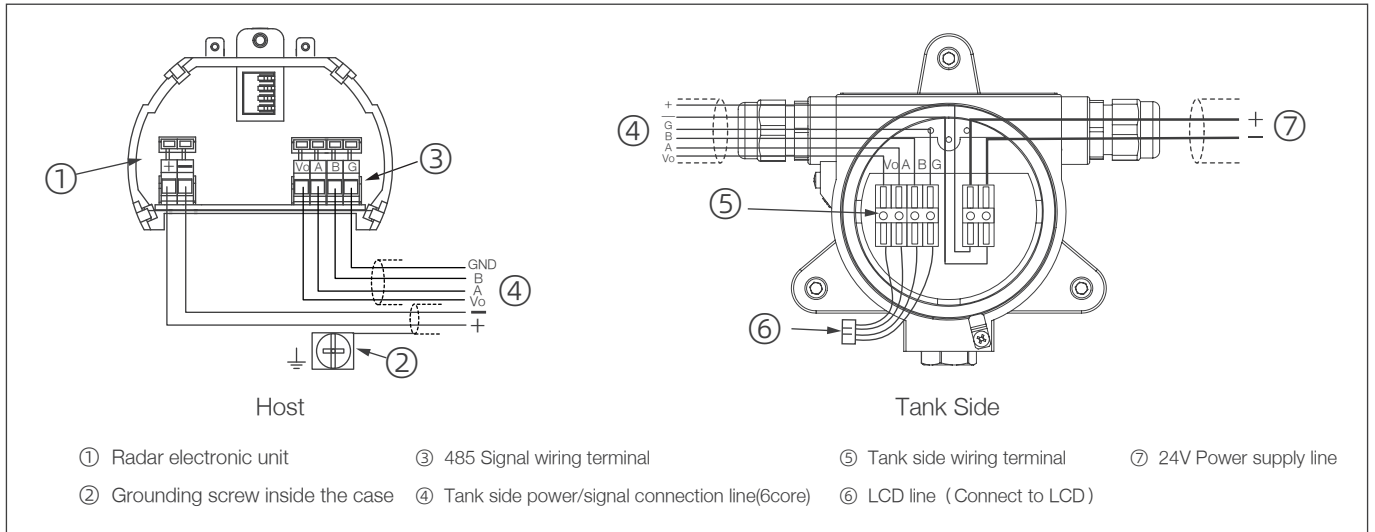

## 24V Single compartment two-wire Modbus output

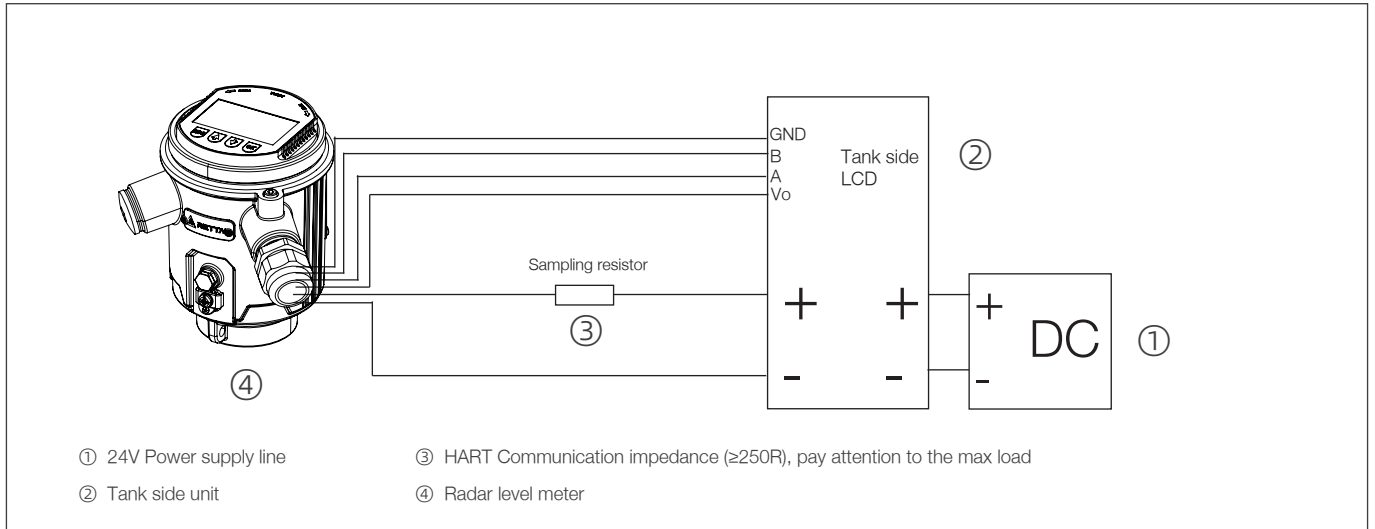

## 24V Dual compartment two-wire passive tank side wiring diagram

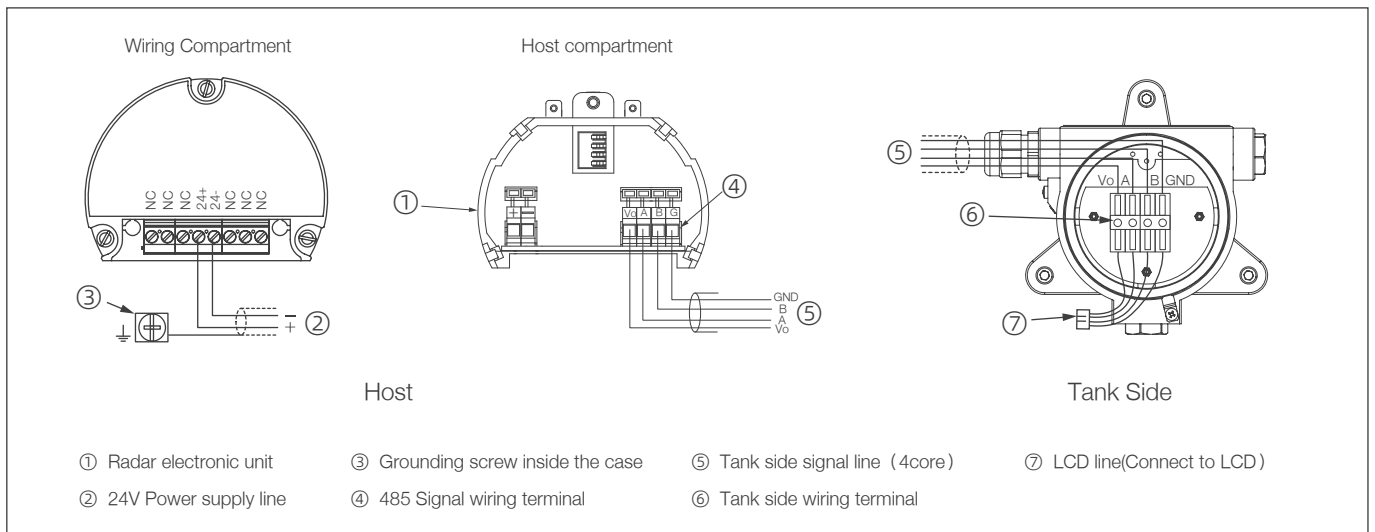

24V Dual compartment two-wire passive tank side 4...20mA HART

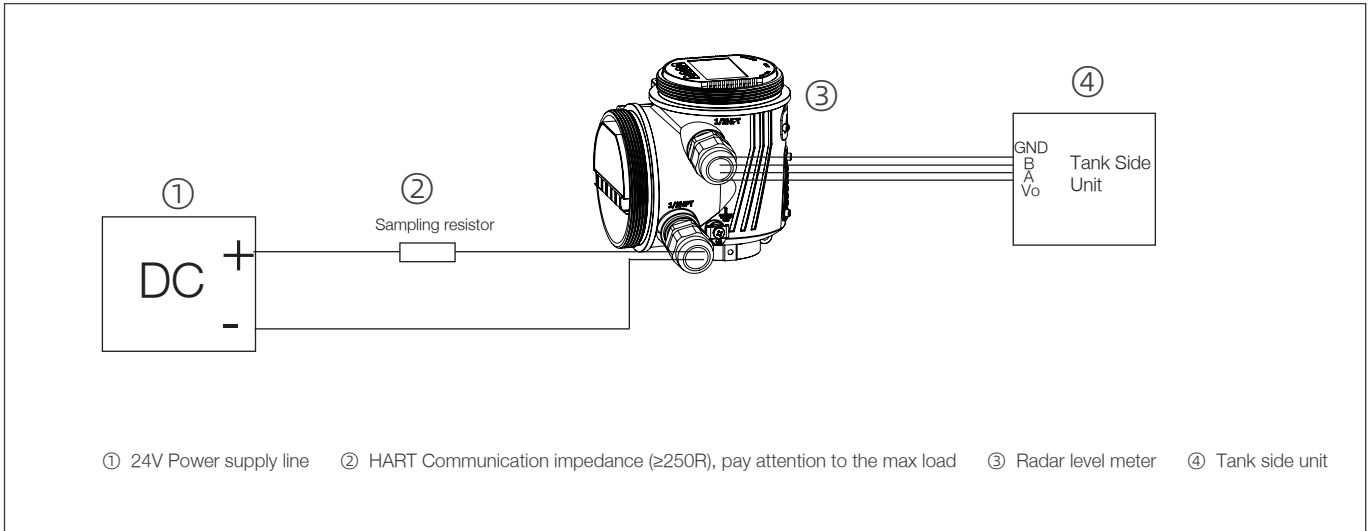

24V Dual compartment four-wire passive tank side wiring diagram

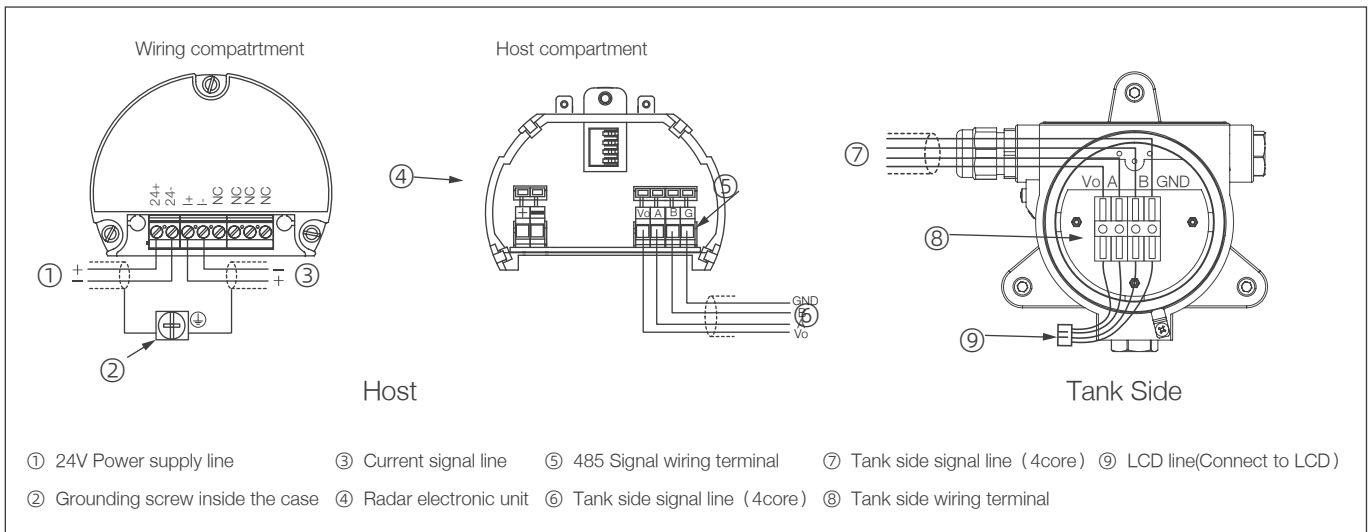

24V Dual compartment four-wire passive tank side 4...20mA HART

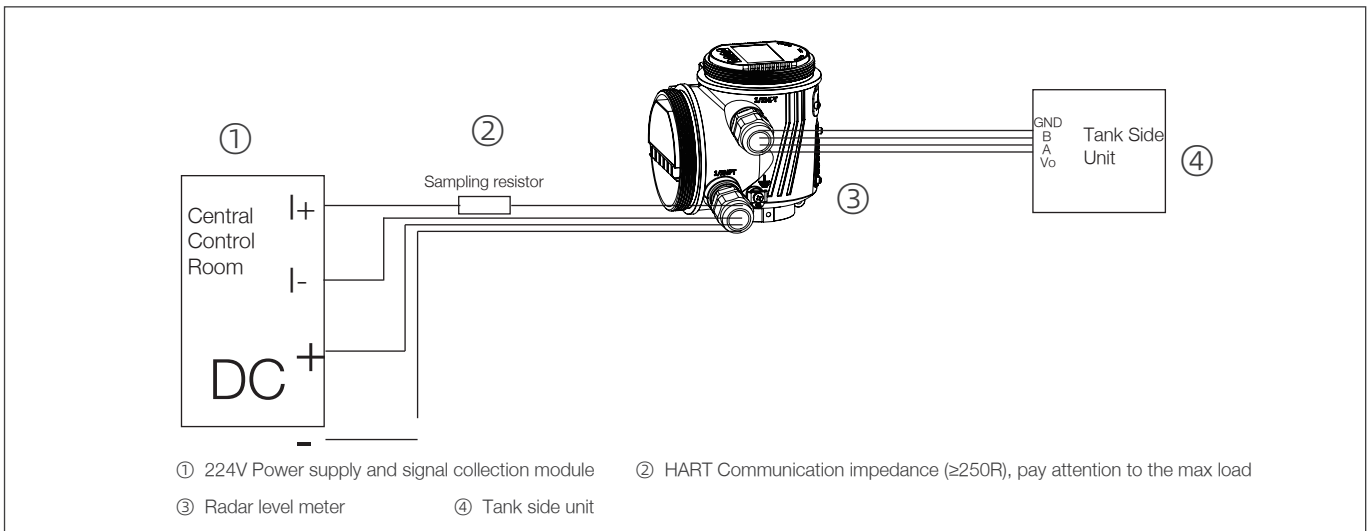

## 220V Dual compartment four-wire passive tank side wiring diagram

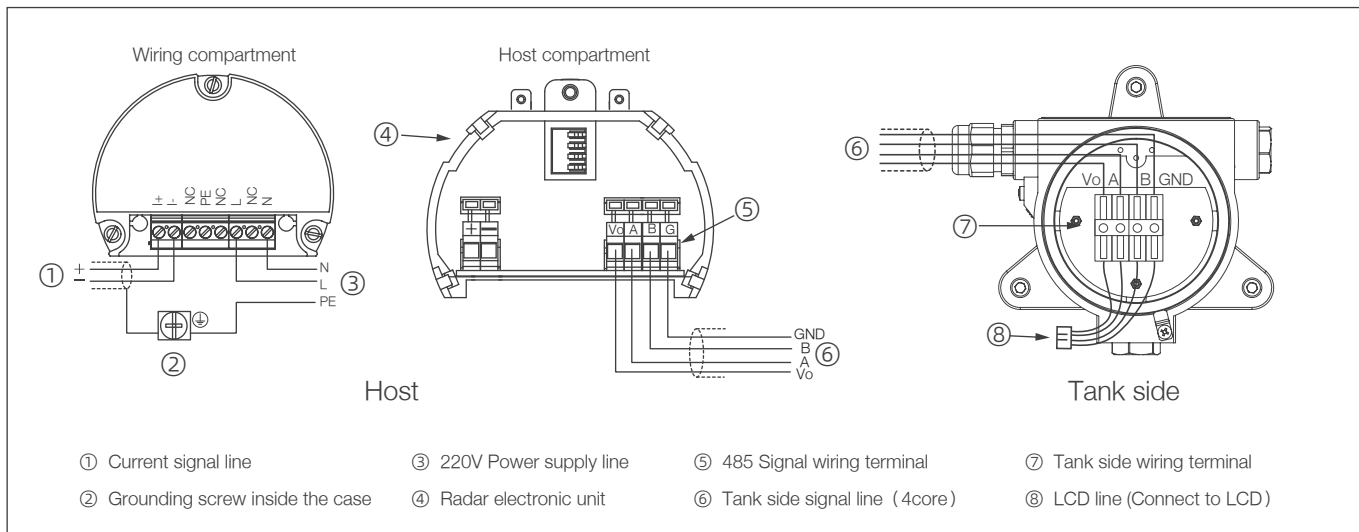

## 220 Dual compartment four-wire passive tank side 4...20mA HART

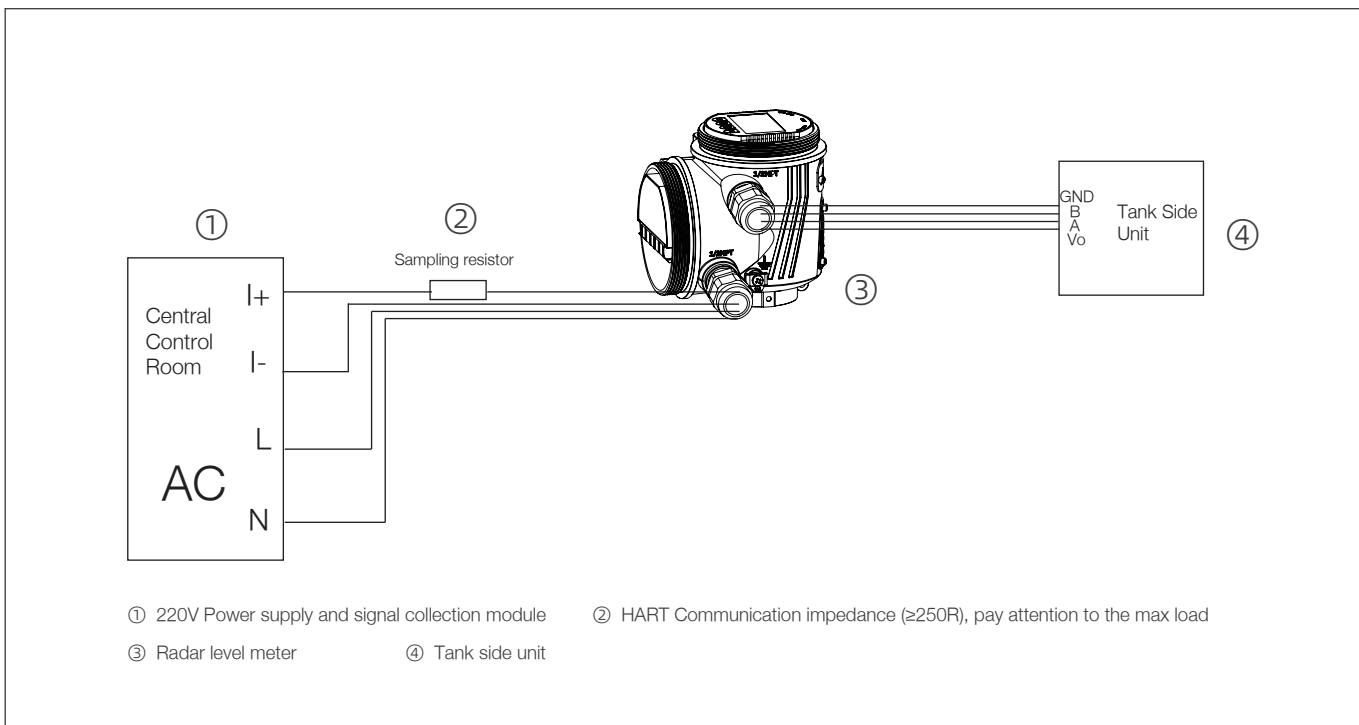

# Instrument Debugging

## Debugging on-site

(1) Display through the LCD display module



(2) HART Communicator (LCD display unit in central control room)

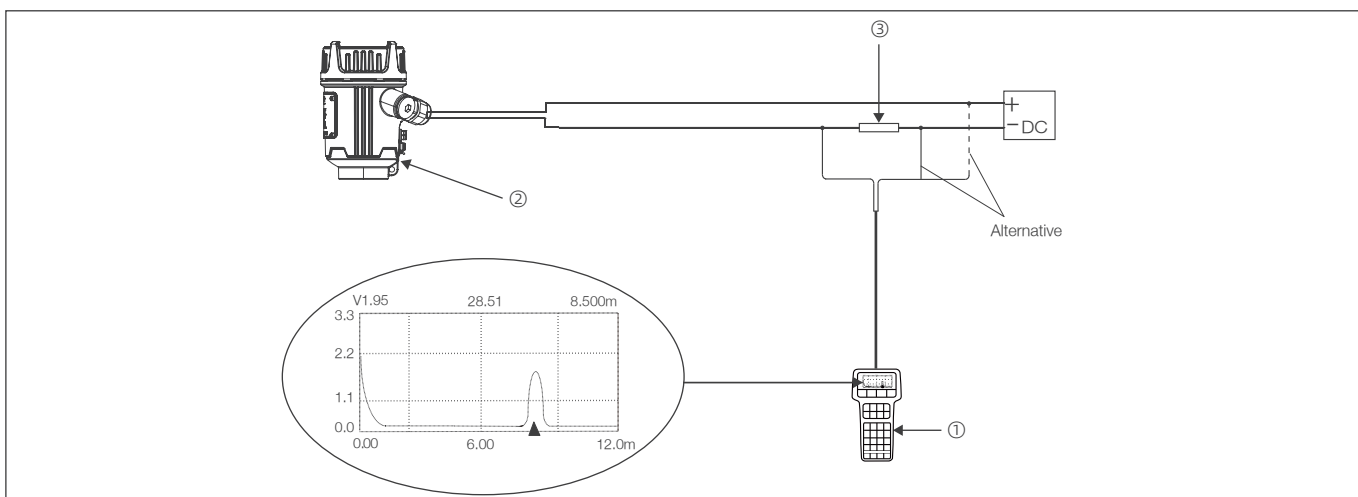

① HART Communicator (LCD display unit in central control room) ;

② Radar level meter

③ HART resistance 250 ohms ( If the DCS in the central control room already has an internal resistance of 250 ohms, this resistance can be omitted, and the Hart handheld communicator can be directly connected to both ends of the control cabinet wiring terminals ) By using an external power source or battery power supply, the Hart handheld communicator can form a LCD display unit in the central control room for long-term observation of instrument operation status.

## Remote debugging

Remote display unit — positive tank side

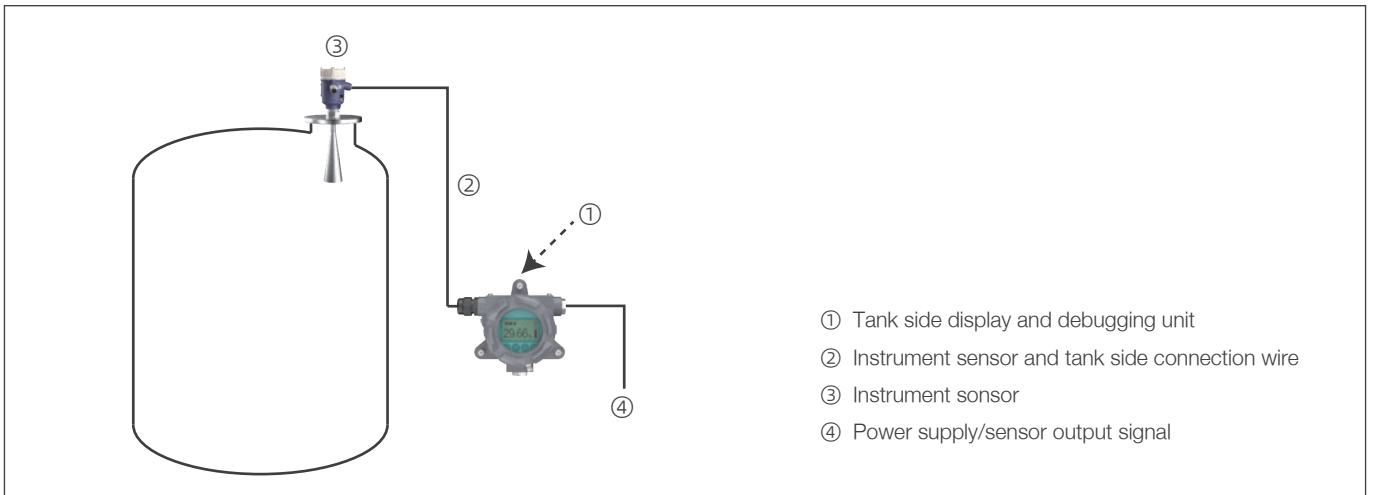

Remote display unit — passive tank side

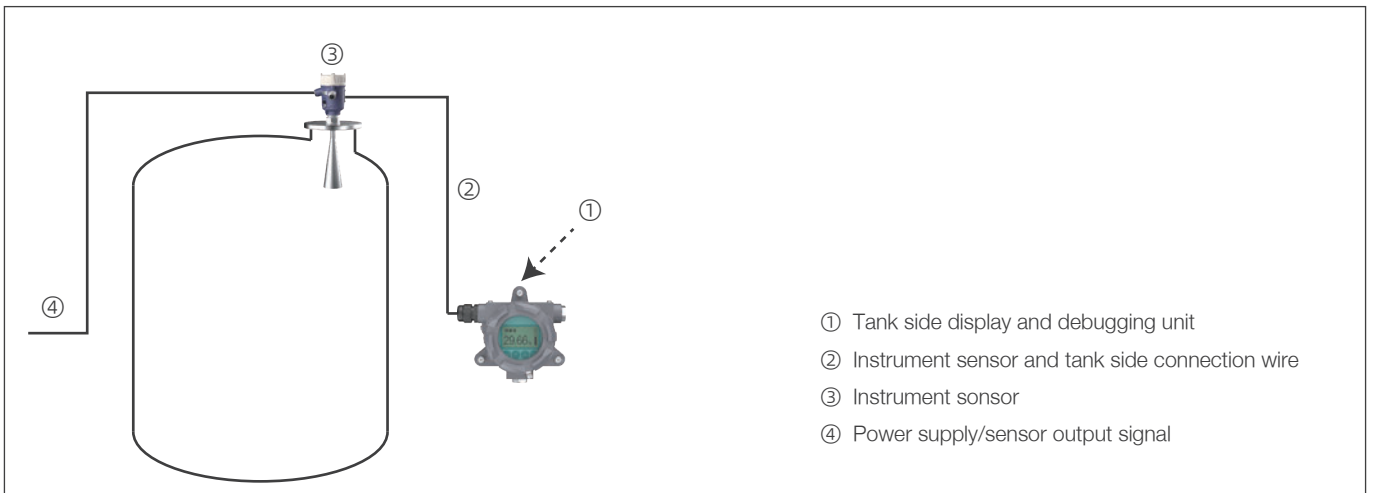

# Structure Size

Single compartment housing size (Note: The values marked in [ ] are in inches, and the rest are in millimeters)

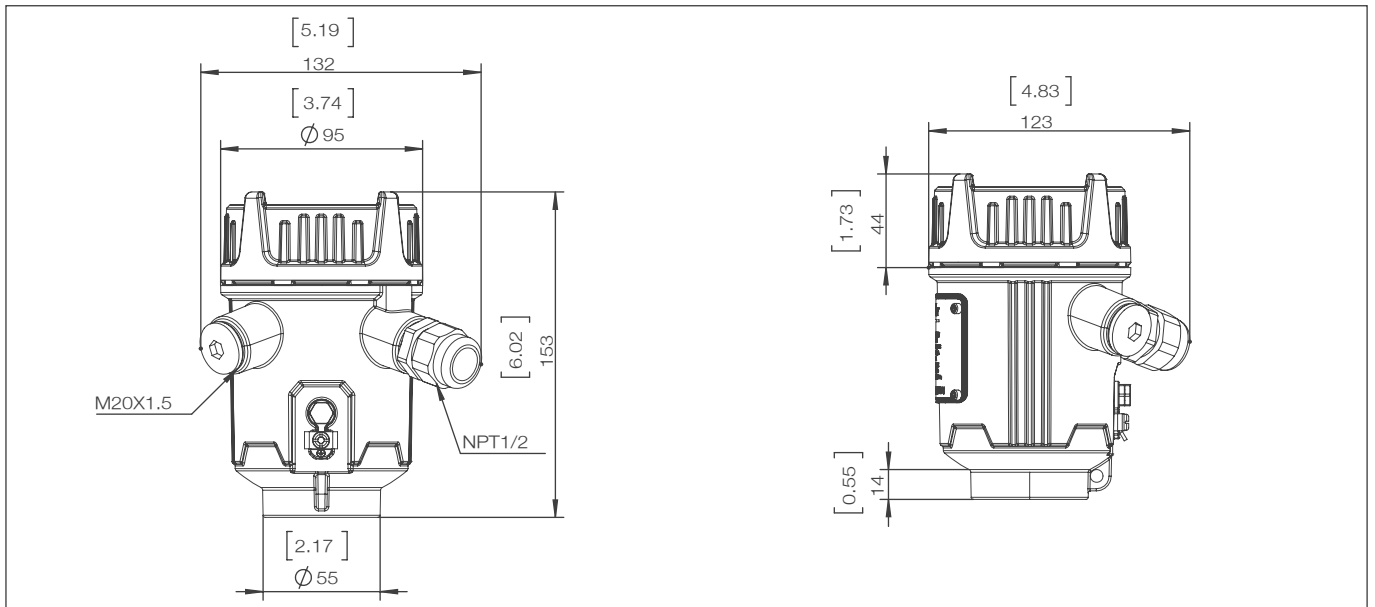

Dual compartment housing size (Note: The values marked in [ ] are in inches, and the rest are in millimeters)

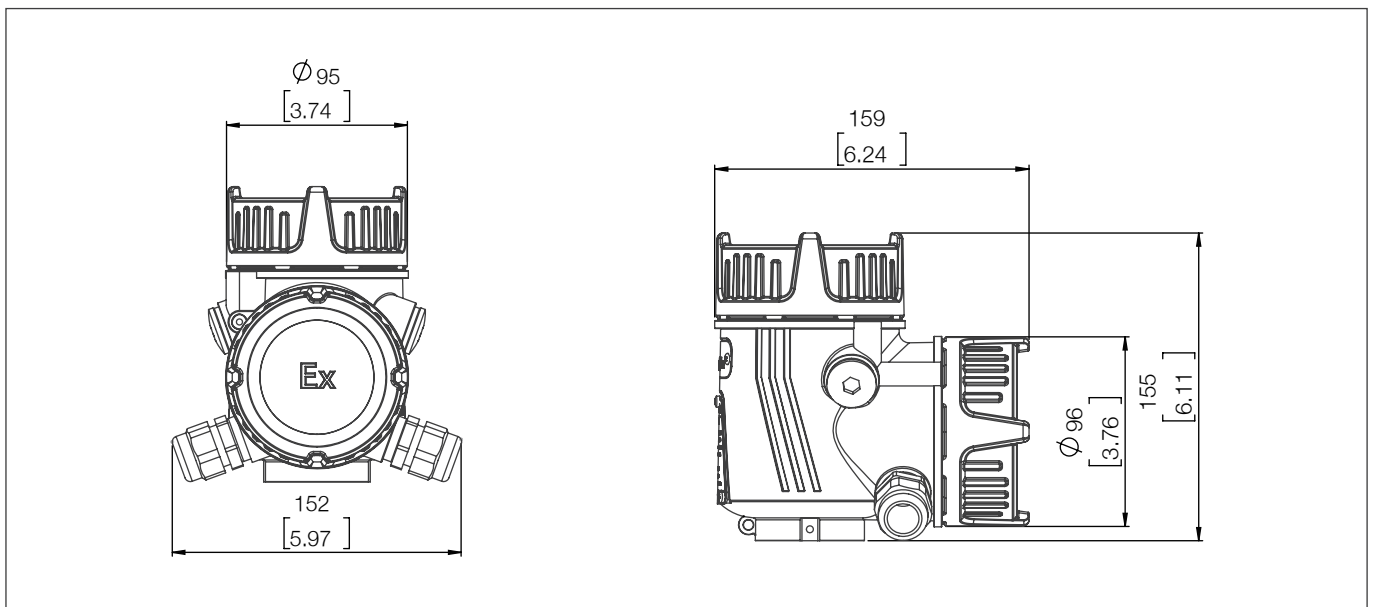

## Instrument Size (Note: The values marked in [ ] are in inches, and the rest are in millimeters)

### CPR6100 Radar Liquid Level Meter With Anti-corrosion Rod Antenna

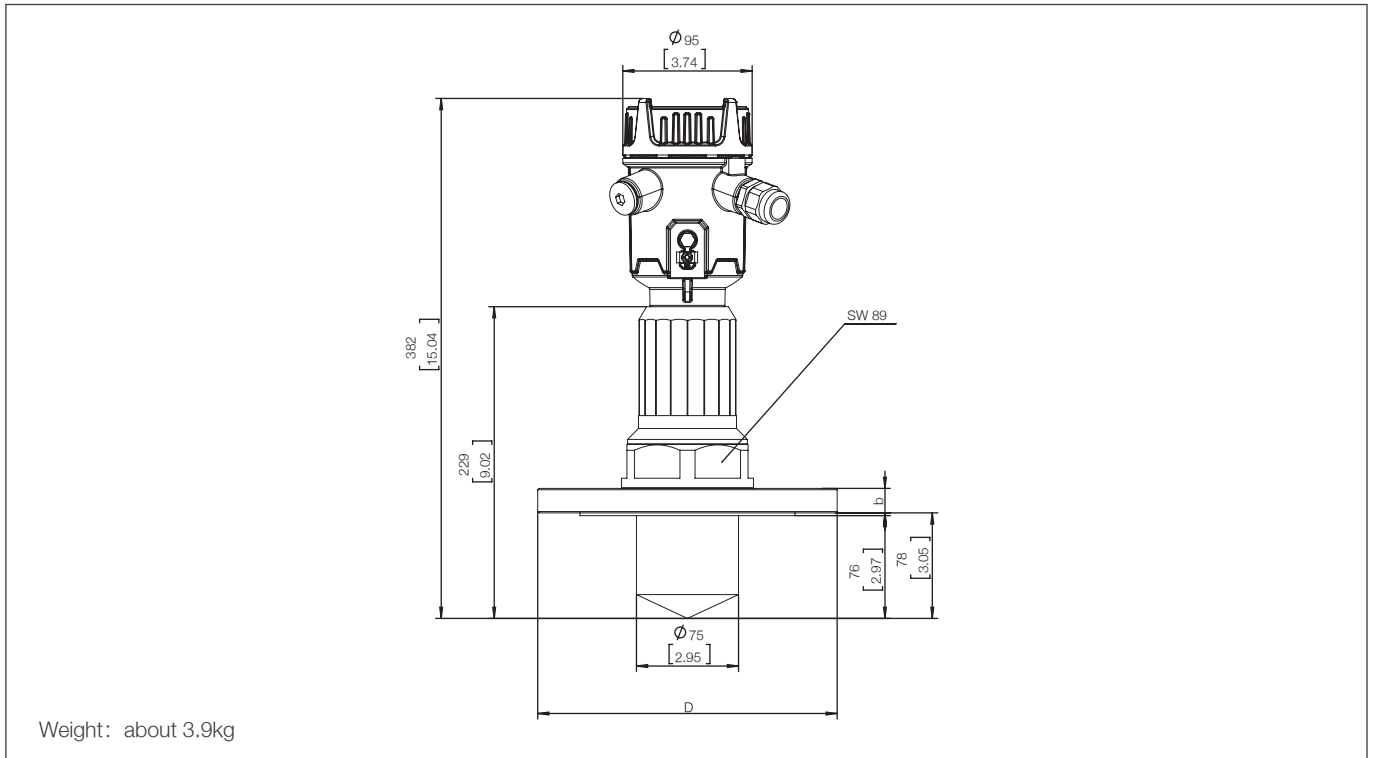

### CPR6200 Radar Liquid Level Meter With Horn Antenna

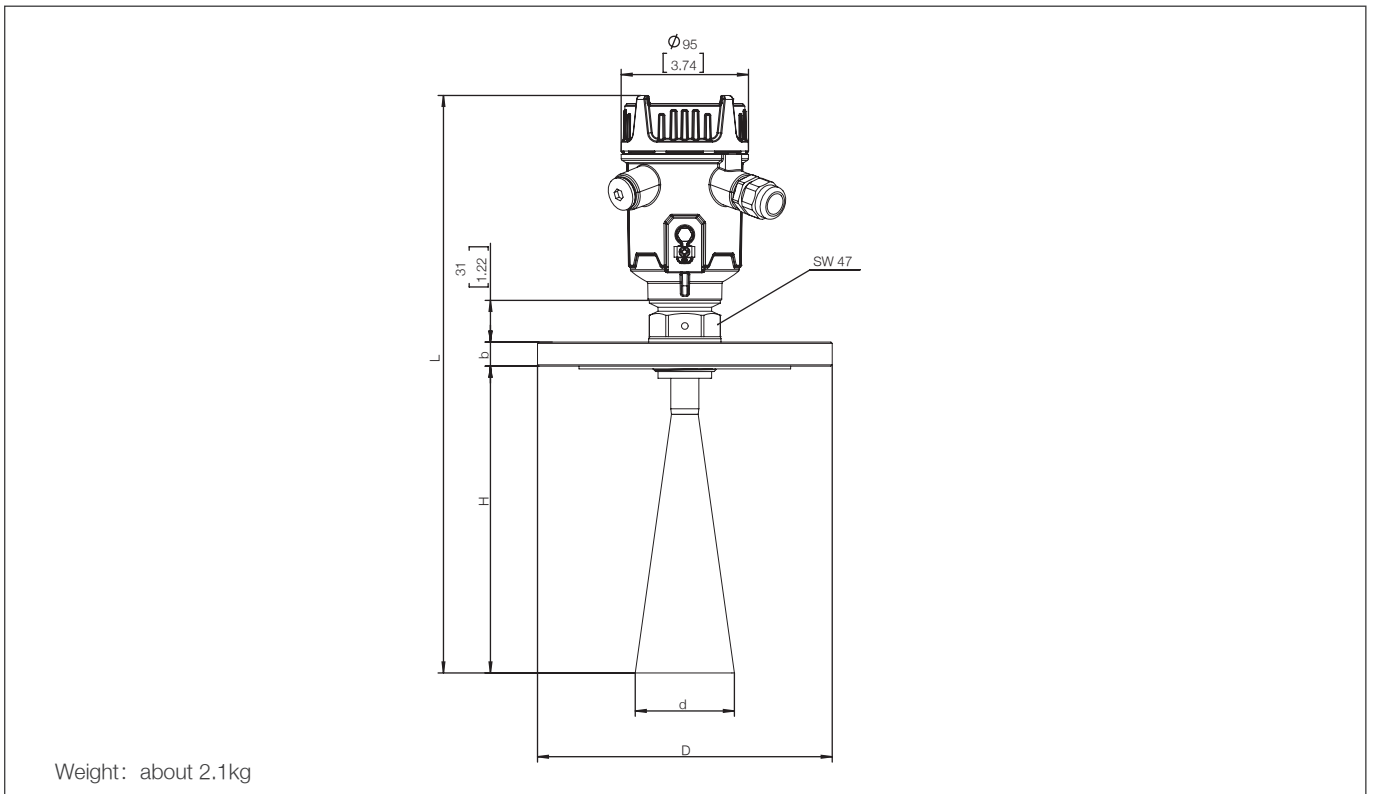

CPR6300 Radar Liquid Level Meter With Anti-corrosion Conical Antenna

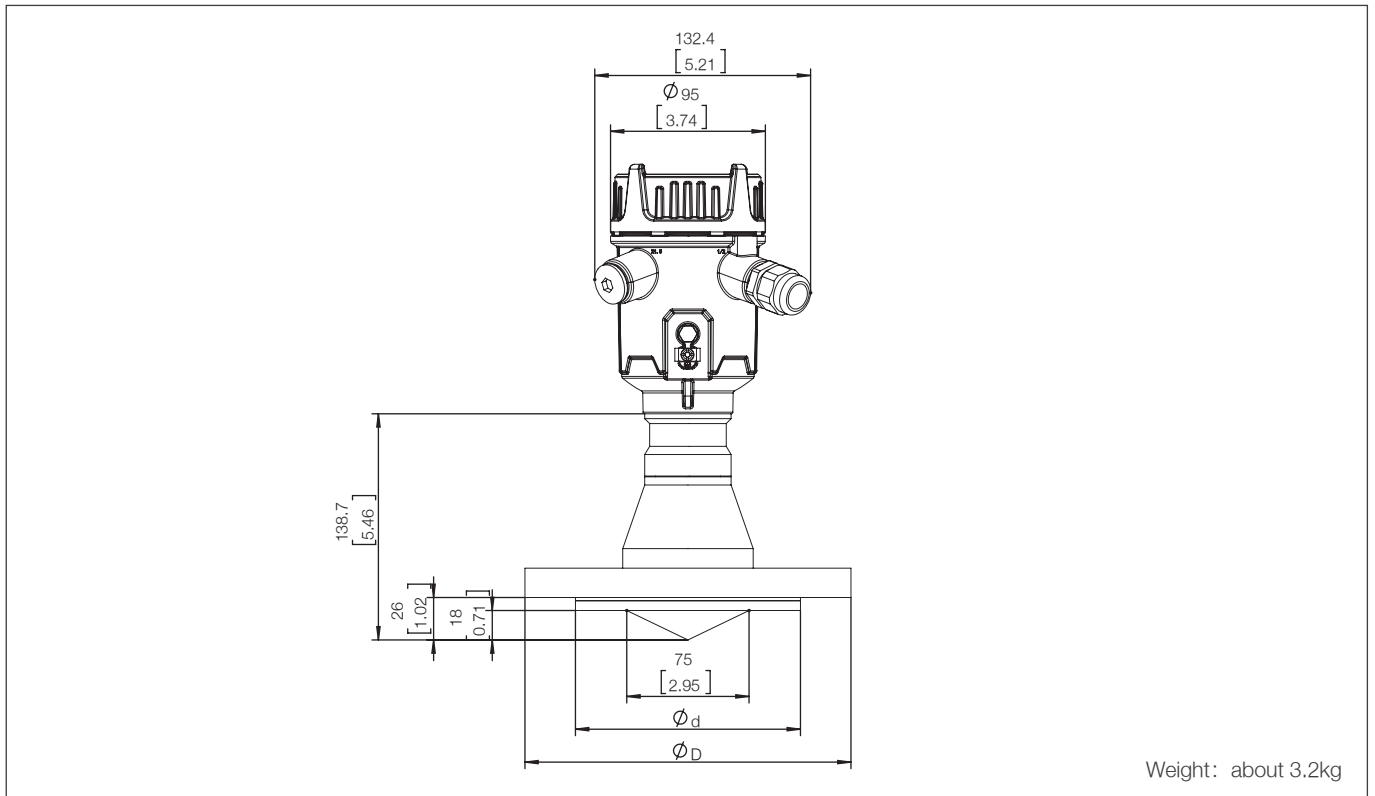

CPR6700 Radar Solid Level Meter With Conical Antenna

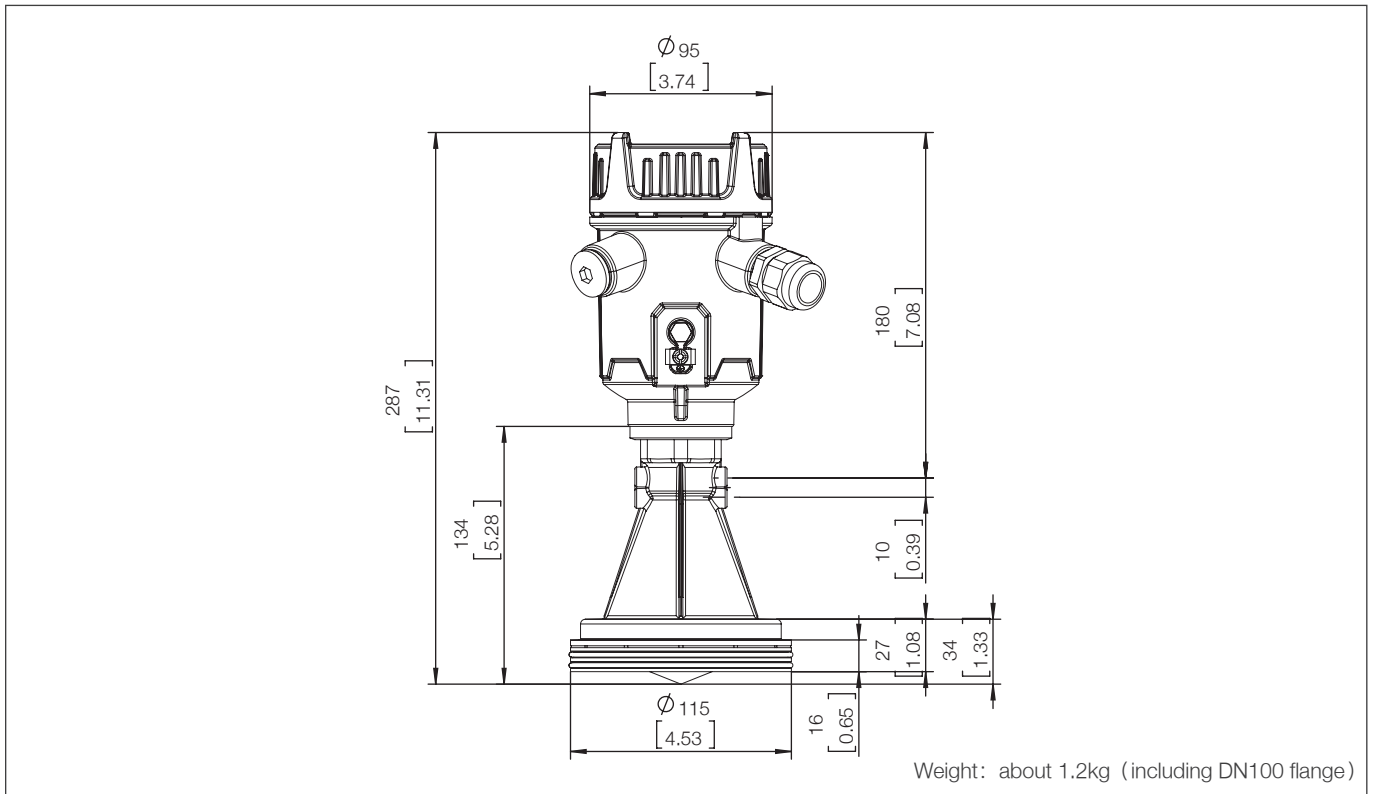

## CPR6800 Radar Solid Level Meter With Parabolic Antenna

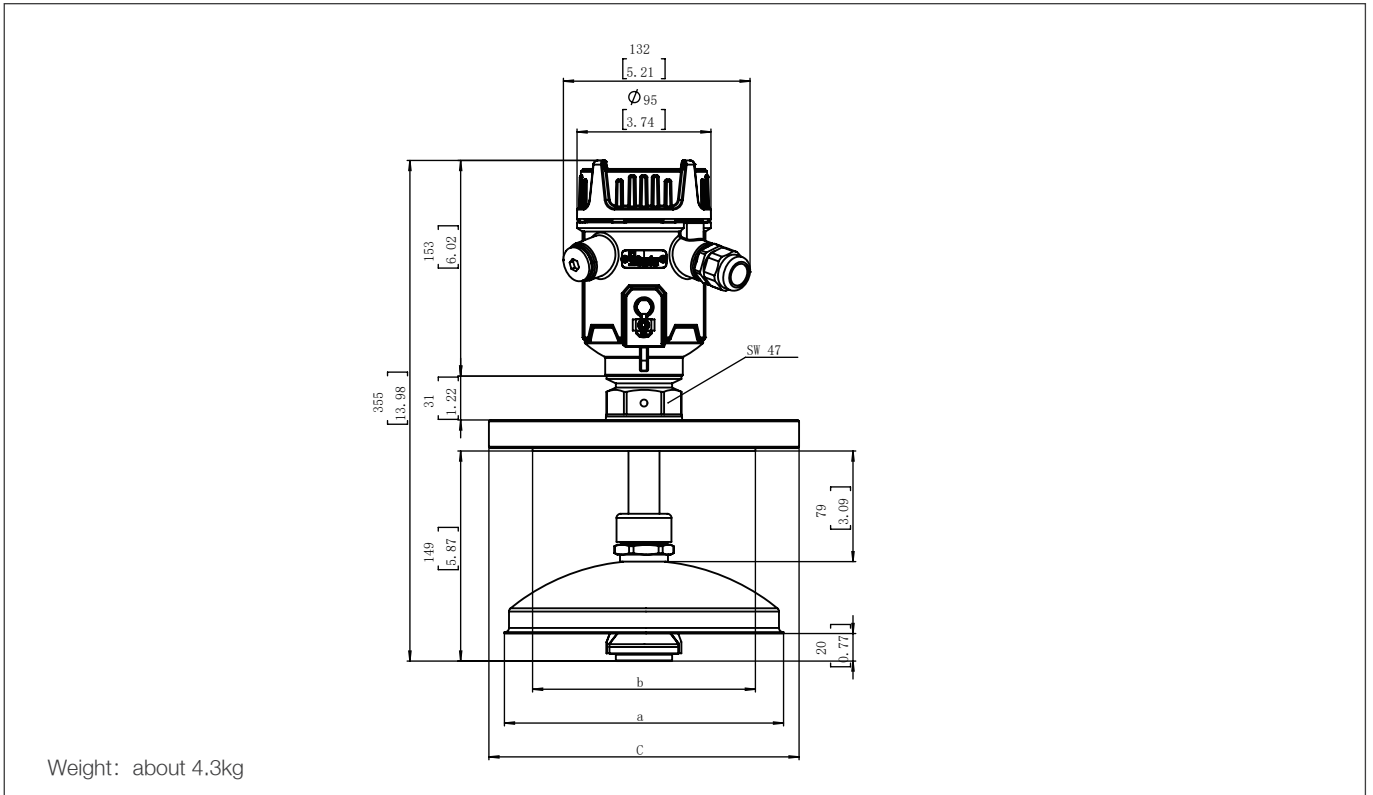

RETTAR

INDUSTRIAL MEASUREMENT INNOVATOR



☎ 400-801-0770

🌐 [www.rettar.com](http://www.rettar.com)

✉ [marketing@rettar.com](mailto:marketing@rettar.com)

📍 Lutong Hongyun Technology Park,  
No. 17 Yunshan South Road,  
Tongzhou District, Beijing